

QL Today

Volume 1
Issue 4
Nov./December
1996

The Magazine about QL, QDOS,
Sinclair Computers, SMSQ...

What do they all
have in common?

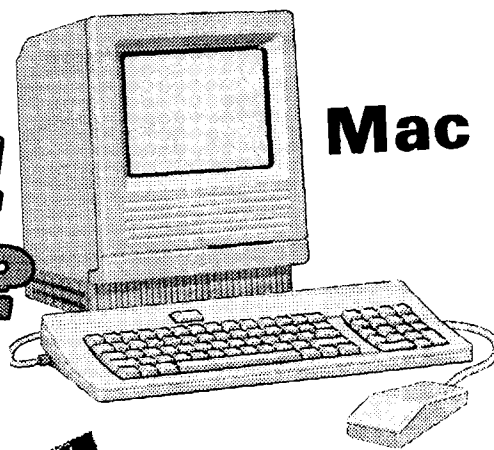

Mac

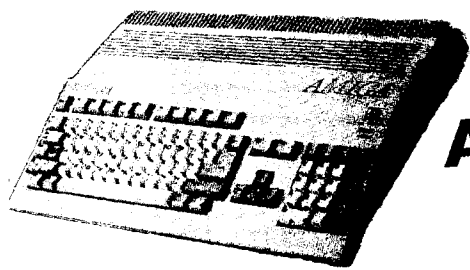

AMIGA

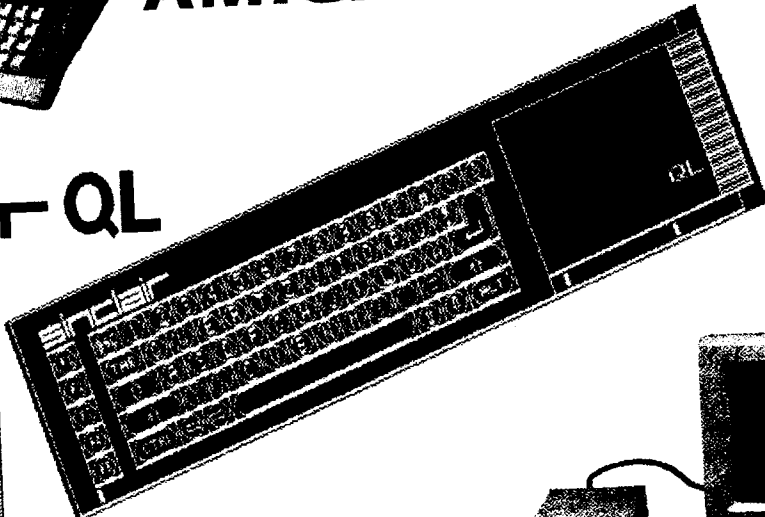

sinclair QL

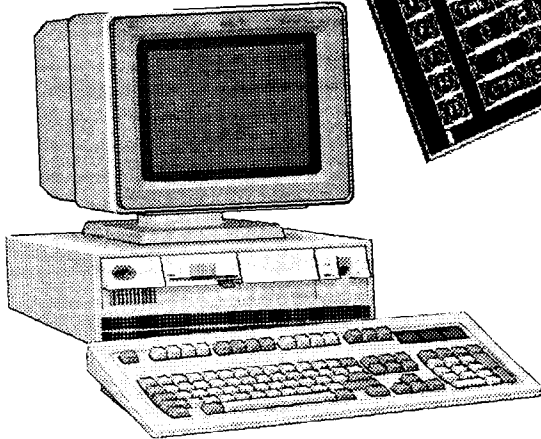

PC



ATARI

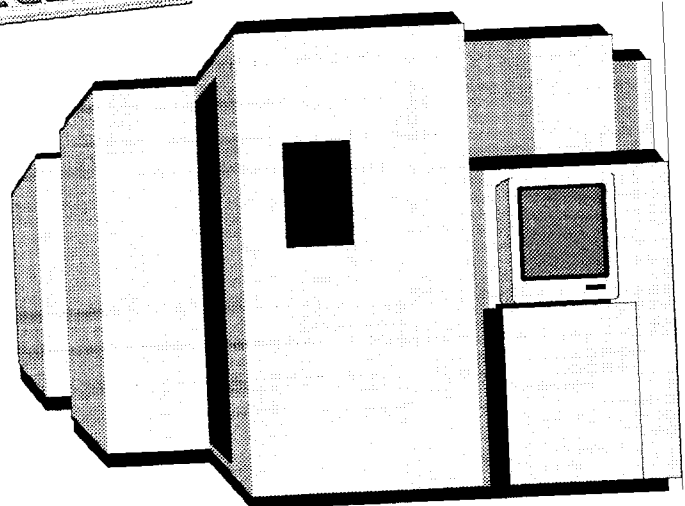

(Unix)

QL Today

German office & Publisher:

Jochen Merz Software
Im stillen Winkel 12
47169 Duisburg
Germany
Tel. +49 203 502011
Fax +49 203 502012
Box1 +49 203 502013
Box2 +49 203 502014

English office:

Miracle Systems Ltd.
20 Mow Barton
Yate, Bristol
United Kingdom BS17 5NF
Tel. +44 1454 883602
Fax +44 1454 883602

Editor:

Dilwyn Jones
41 Bro Emrys
Tal-Y-Bont, Bangor
Gwynedd
United Kingdom LL57 3YT
Tel. +44 1248 354023
Fax +44 1248 354023

QL Today is published bi-monthly, our volume begins on 15th of May. Subscriptions begin with the current issue at the time of sign up. Subscription rates are as follows:

Germany	DM 70,-
England	DM 60,- or £25
Rest of the World	DM 70,- or £30

Payment in DM (drawn on a German bank) can be made by either Cheque or Euro-Cheque, Payment in £ (drawn on an English bank) can be made by Cheque. Cheques should be made payable to Jochen Merz Software (German office) or Miracle Systems Ltd. (English office).

Credit Card holders may subscribe by either calling or sending their Credit Card number and Expiry date. Credit cards will be charged in DM (German office) or in £ (English office).

We welcome your comments, suggestions and articles. YOU make **QL Today** possible. We are constantly changing and adjusting to meet your needs and requirements. Articles for publication should be on a 3.5" disk (DD or HD) in ASCII, Quill or text87 format. Pictures may be in _SCR format, we can also handle GIF or TIF. To enhance your article you may wish to include Saved Screen dumps. PLEASE send a hardcopy of all screens to be included. Don't forget to specify where in the text you would like the screen placed.

Article and Advertising DEADLINES are as follows:

Issue 1: 15 April	Issue 2: 15 June
Issue 3: 15 August	Issue 4: 15 October
Issue 5: 15 December	Issue 6: 15 February

QL Today reserves the right to publish or not publish any material submitted. Under no circumstances will **QL Today** be held liable for any direct, indirect or consequential damage or loss arising out of the use and/or inability to use any of the material published in **QL Today**. The opinions expressed herein are those of the authors and are not necessarily those of the publisher.

This magazine is copyrighted and all material published remains the property of **QL Today** unless otherwise specified. Written permission from **QL Today** is required before the reproduction and distribution of any/all material published herein. All copyrights and trademarks are hereby acknowledged.

Contents

- 3 Editorial
- 4 News
- 7 **QL Today Survey** - Dilwyn Jones
- 9 **Talk to Me!** - Roy Wood
- 10 **PGP (Pretty Good Privacy)** - Tim Swenson
- 13 **Di-ren's Internet** - Robin Barker
- 16 **QL Service List - Part 3** - Robert Klein
- 18 **QMenu - Part 2** - Dilwyn Jones
- 22 **QL Serial Ports** - H.-Peter Recktenwald
- 28 **Q-emuLator, QL on the Mac** - Al Boehm
- 32 **Bugs 'n Fixes**
- 35 **Master Spy & Spy Review** - Roy Wood
- 35 **QFormat** - Dilwyn Jones
- 38 **Noughts & Crosses** - Ron Humphries
- 39 **Amiga "QDOS"** - Simon N. Goodwin
- 42 **Comment: Future imperfect?** - Jonathan Hudson
- 46 **Letter-Box**
- 47 **Snippet's Corner I** - Mark Knight
- 50 **Easy Export from Z88 Pipedream into Quill** - Beryl & John Crawley
- 50 **"Just Words" reply** - Geoff Wicks
- 52 **Black Knight Review** - Mark Knight
- 54 **ATARI QL-Emulator** - Jochen Merz
- 55 **QPC** - James Hunkins
- 61 **Last Minute News**
- 62 **UQLX** - Richard Zidlicky
- 62 **Editor's last Word**

Advertisers

in alphabetical order

Di-Ren	63
Jochen Merz Software	19
Miracle Systems Ltd.	53
PROGS - Van der Auwera	9
QBranch	23
QBOX USA	43
Quanta	45
Quo Vadis Design	31
Qubbesoft	41
W.N. Richardson (EEC)	27
TF Services	15
S.J.P.D. Software	37
Geoff Wicks	55

Editorial

Dilwyn Jones

Well, despite my PC's attempts at disrupting this issue (it broke down weeks ago and I'm having trouble getting it repaired), we made it in the end. See the cartoon Jochen has placed on this page for how I felt. Let's just say that between our combined experience of PCs Jochen and I will be sticking to QDOS/SMSQ where we can possibly avoid using anything else for the foreseeable future!

So I bought an external modem. Now, I am not one of those people who take to modems like ducks to water, so this may be a traumatic experience for me. Comms is one of those issues where I have little faith in my own ability to master the subject! I'll let you know in a future issue how I got on, once I've ploughed through the QTPI software's extensive manuals!

The big software launch of the last couple of months was QPC, allowing us to run SMSQ/E in software on the PC without the need for expensive hardware add-ons. We now have a good choice of platforms on which to run our software. PCs, Amigas, Macs and Ataris can now be enhanced with the addition of QDOS or SMSQ operating systems.

In this issue we have articles about QPC, Amiga emulator, and Q-emuLator for the Apple Mac, and the Atari emulators. With all this choice, do

we need the old QL? Is it outdated? The answer to both questions is 'yes'.

The big hardware launch of this year looks like being the Aurora card, bringing both a new QL hardware motherboard and enhanced graphics. We have waited so long for enhanced graphics on the standard QL that Qubbesoft P/D need to be sure of getting right first time. Unfortunately, it looks as though it will be launched without drivers for the enhanced colour modes, but at least it will be possible to add these via software later.

1996 looks like being a good year for the QL after all.

The results of the survey we organised in issue 2 are printed in this issue. We had a very good response, with some interesting views and not a few surprises!

One of the things which became obvious was that we need reviewers for the huge collection of public domain and freeware applications out there for the QL - I suppose there is so much out there from the BBS's, SJPD, Qubbesoft and even Quanta that people want to know what's good and what's bad. We've made a start, but an appeal to you the readers: you must have used some good (or bad!), free or low cost programs for the QL. Why not write a short review of a program you have used, so that our readers know what it's like? Send us a text file on disk about the program, along with a screen copy from the program if possible. If you fancy seeing your name in print, do get in touch.

■

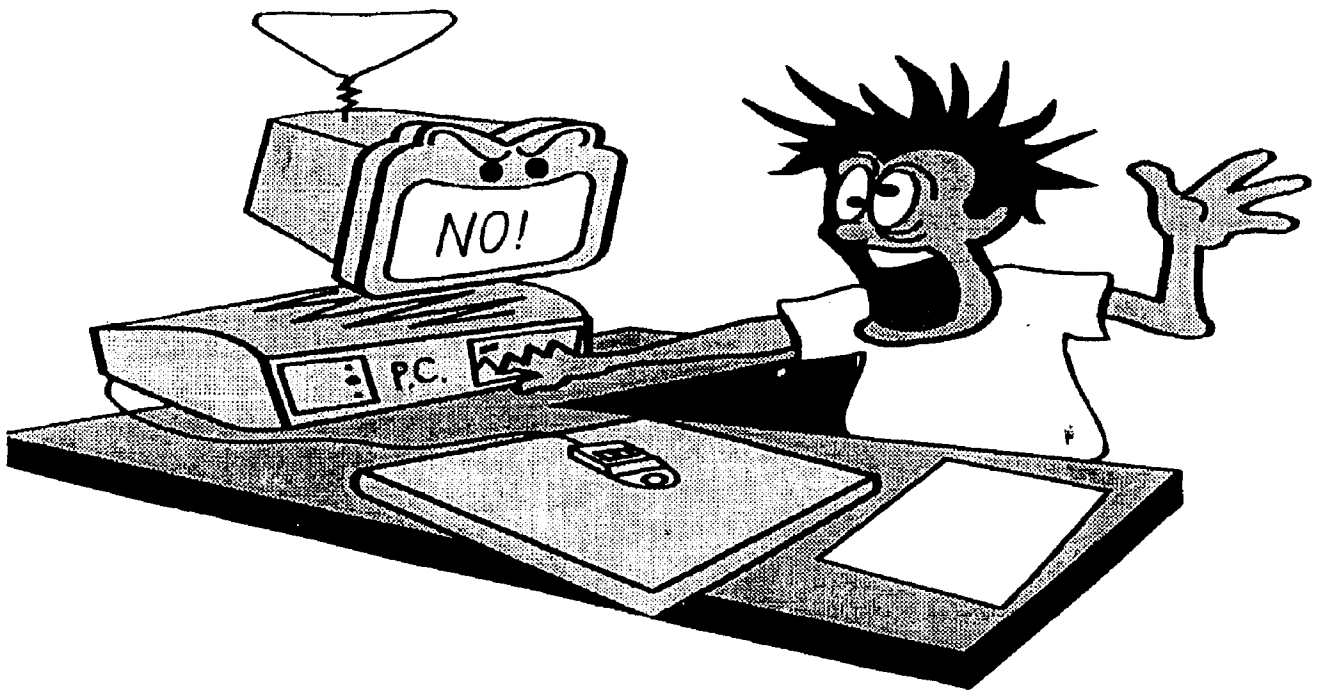

News & Updates

QL Club International

(Update to the QL Service List)

Mike Keneally asked us to publish the following information to update the information in the QL Service List:

Tel. (+44) 1625 878207

Fax (+44) 1625 260072

Email: 106114.710@compuserve.com

Club QL International's 91st issue of their disk-based magazine should be available by the time you read this. Issue 90, in addition to the usual members' letters, contains such delights as a list of National Lottery numbers for use with Abacus, and Exorcist, a utility for use with Ghosscript. Membership is free. Just send a floppy disk for your copies of the monthly newsletter with return envelope, address label and postage, to arrive by the 28th of the month. The editor, Mike Keneally, suggests that you show your support for the group by including a letter or article on the disk for inclusion in the disk magazine. Mike Keneally, Club QL International, 6 Barnaby Road, Poynton, Cheshire, SK12 1LR, England.

68K Club Moves

The Birmingham and West Midlands QL & 68000 club is moving back into the City centre after a few months in Hockley, at a pub which was rather more difficult to reach than the Holloway - our home for more than ten years, now alas turned into a 'fun pub'. The new venue from October 1996 onwards is the Queen's Head, near Steelhouse Lane, in the City Centre. We meet two evenings a month, on the first and third Mondays of the month, except when that's a bank holiday.

For more information contact Mike Bedford White on 0121 708 2560 or by post at 16 Westfield Road, Acocks Green, Birmingham B27 7TL.

Di-Ren eMail Address & News

Due to Email difficulties with our ??@di-ren.demon.co.uk Email service, it is possible not all Emails have been received by us. If you have not had a reply to a recently submitted letter, please re-send.

In any event please note our new Email address and update your records accordingly:

di-ren@di-ren.co.uk

With any luck this should be the last ever change as it refers to our own domain (di-ren.co.uk), not the current service provider we happen to be using.

Di-Ren will be closed for all business between the following dates: 25th November to 16th December, 24th December to 2nd January

<http://www.di-ren.co.uk> file requests are handled in the same manner, i.e.; to retrieve a file via Email, send:

Email address: di-ren@di-ren.co.uk

Subject: ** Anything will do here!**

Body: AUTO SENDFILE file-name (for instance, AUTO SENDFILE ql/homepage.htm)

Unfortunately, Di-Ren is currently unable to source the "keyclick" variety at sensible prices - pity, because they were good value for money.. The other 102 key Enhanced type Di-Rensupply have gone up in price from £18.00 to £24.00 (these are also good quality keyboards).

"Just Words" Update

NEW TRANSATLANTIC THESAURUS

A data base with USA English spellings is now available for QL-THESAURUS.

This is in response to Gary Norton's wishes in his QL TODAY review of the program.

Apologies to UK customers who may have ordered software from me and have not yet received the goods. The postal situation has deteriorated rapidly in the last month. Two airmail letters have taken a fortnight to arrive and surface mail seems to have dried up completely. I fear that I will not receive some orders until the postal dispute is over.

PLEASE USE ONLY AIR MAIL!

QBranch and Quo Vadis Design stock the full range of my software, including QL-Thesaurus upgrades.

Quo Vadis Design News

Quo Vadis Design have announced that they have appointed a new trainee to their staff. Bruce Nicholls' second daughter, Roseline Nicholls, was born on Monday 23rd September 1996, weighing in at 7 pounds 8 ounces (3.4kg). Both mother and baby are said to be fine.

Quo Vadis Design now have a version of Flashback Special Edition (or more specifically, its Report Generator), compatible with SMSQ/E, thanks to some hard work by Rich Mellor. The upgrade costs just £2.50 from Quo Vadis Design, and you should send the original Flashback SE master disk as proof of purchase. Quo Vadis Design will add the revised files and return the disk to you.

News From TF SERVICES

At the end of October, TF Services will be producing two new hardware add-ons for users who make use of the I2C interface on the Minerva Mk2 serial bus.

The first is a Power Driver Interface, which has the same 16 TTL input/output (I/O) lines as the

current parallel interface, but also adds 8 high power switches for motors, relays, etc. There will be two types, allowing 1.5 and 3 amps total current respectively. Each output can source or sink current, allowing, for instance, a pair of outputs to reverse rotation for one motor, or drive two motors in a single direction.

The second device is called Relays. This product will plug directly into the power driver, and provide eight 2amp mains relays.

At the time of writing, prices had yet to be announced. Contact TF Services for further details.

News from Jonathan Hudson

Richard Zidlicky is making good progress in producing a Unix version of Danielle Terdina's Q-Emulator (as currently available for the Mac). A version is functional on Sun (big endian architecture (like the 680x0) CPUs) and an alpha version on Linux (Intel, little endian architecture) has progressed to the state of booting a ROM image and presenting a cursor. This emulator runs in an X window on your Unix desktop.

More information on this exciting development from rdzidlic@cip.informatik.uni-erlangen.de.

Jonathan Hudson has upgraded the QFAX suite to support Class 2.0 fax modems in addition to the existing Class 2 support. Class 2.0 is the future of fax modem technology and is available many newer modems on the market (e.g. USR models). QFAX 2.80 also features some bug fixes, a few new features, and a general speed up (low end CPUs send/receive, faster printing and fax encoding). More details from jrh@jrudson.demon.co.uk.

A QDOS port of Angus Duggan's 'psutils' package (ported by Jonathan Hudson) is available from QDOS BBS.

These utilities may be used to reorganise PS (Postscript) files prior to printing with Ghostscript (the great, free, Postscript interpreter). In particular, 'pstops' can convert an A4 document into a double-sided A5 booklet, dramatically reducing the number of sheets required.

If you've balked at printing the 70 A4 QTPI PS document, you can now have it instead as a neat, 18 page, A5 booklet using 'pstops'. All you have to do is pass the paper through the printer twice (to print the reverse sides). Highly recommended for Ghostscript fans.

Jonathan also pointed out that his QTPI pointer driven terminal program can in most cases successfully drive external PC modems via their COM ports on a QXL. Given my own dreadful experience of using modems and communication software on a PC, this has to be good news. Jonathan's QFAX and QTPI software are freely distributable programs, available from most PD libraries.

QL Show in Brighton

Roy Wood of QBranch has informed us that he is planning to organise another QL meeting in the area around Brighton. The first weekend in February would be a good date, but it is not confirmed yet. However, if you plan to visit the show (and there is no reason why not!) then mark this weekend in your agenda. The January issue of QL Today will contain more detailed information about the show, but as it is shipped in the middle of January it is possible that you will receive it just a few days before the show.

JOCHEN MERZ Software News

FiFi II: The very useful FileFinder Utility by Wolfgang Lernerz has been upgraded, and a lot of features were added: first of all, FiFi II does really multitask. All the files found by FiFi are now placed in a list step by step (not as before, when FiFi's search finished) so that you can see and examine the files already found while FiFi carries on searching. This amazing feature is unique in the QL program world: a list which can be scrolled through and items can be selected while it is dynamically updated! Of course, there are lots of other new features: FiFi's search can be stopped (without removing FiFi, of course), you can search for words, give a list of file extensions to be searched or not to be searched, exclude the scanning of subdirectories etc. FiFi II is already available - the upgrade is only DM 19,90.

QPC: QPC comes as Version 1.03 - new features include the option to use COM1 to COM4 and it can be installed on ZIP-drives. Marcel Kilgus, the author, is working on a 1024x768 display mode, but no promises can be made yet.

SMSQ/E + QPAC2: SMSQ/E in its current version 2.77 can now display all the detailed channel information which was missing before. You need QPAC2 V2.37 (or higher) to get this information displayed in the channels menu. It will tell you all the details about open channels, e.g. SER2T or PARDR or PIPE_FRED (in) etc. QPAC2 has been upgraded to Config Level 2, which makes configuration now so easy.

QL GENEALOGIST News

Chris Boutal, author of the QL Genealogist programs, has advised me that version 3.20 of the program is now available, which fixes a minor bug in the previous versions. For upgrades, send the master disk of Genealogist 3 back to him along with return postage.

Chris has also produced a PC version of this software. This may prove useful if you are a Genealogist user, and have a friend who would like to

share your data, but has not seen the light and acquired a QL, for Chris supplies a program to allow data to be exchanged between the PC and QL versions. The idea of producing cross-platform applications is not entirely new - you may remember that a few years ago, Di-Ren produced a PC version of their Fleet Tactical Command software.

Users of the QL version of Genealogist can purchase the PC version for £40.00, while it costs £55.00 if you are not already a user of the QL version.

Chris Boutal, 21 Proctors Road, Wokingham, Berkshire, RG11 1RP, England. Telephone (+44) 1734-787243

News From PROGS

PROGS have finally released their new PROWESS package. PROWESS is a new application support package, which consists of libraries and applications. PROWESS can be regarded as an extension to the old Window Manager software, but is in reality more than that, as it includes all the system extensions from PROGS, such as PROFORMA and the DataDesign engine.

PROWESS contains some utility software, such as the PROWESS READER, a program to display and print hypertext files. This means that the text can have formatting information included, along with the facility to display pictures and references to other text, either in the same file or another file. The industry standard HTML (Hypertext Markup Language) format, as used in World Wide Web pages, for example, is used.

PROGS will be using this reader to reduce the cost of their software, because they will no longer have to supply printed manuals (although they can be purchased separately if you wish) since the manuals will now be supplied in a format suitable for use with the reader, allowing you to read and print the manuals as you wish.

PROWESS also includes PROFORMA, a vector graphics system, as previously supplied with programs like Line Design.

PROWESS costs 2400 Belgian Francs (about £55.00) plus postage.

Printed manuals are available from PROGS at a rate of BEF2 per page - contact PROGS for more details.

PFLIST: A new version of PFList has been produced, to show off the power of PROWESS. This is a program to create listings on any printer, especially inkjets or lasers, using the facilities provided by the PROGS extensions. The price is now reduced to BEF 600 (about £14.00)

FONTPACK: The Proforma Bitstream Font-pack, containing 100 high quality fonts, is now reduced in price to BEF3000 (around £70.00).

This package may be discontinued soon, due to the expiry of the licence required to sell them.

DATA DESIGN: Bernd Reinhart has re-worked Data Design, removing some bugs and improving the user interface, including the addition of icons to the display. The new v4 of Data Design costs BEF1200 (around £28.00).

Updates for Data Design and PFList are free when master disks are returned with an order for another program, otherwise PROGS say they will only charge for postage for upgrades.

News From QUBBESoft P/D

QUBIDE: The Qubide ROM is now at V1.51. V1.50 added the facility to read alien media via the introduction of a direct sector access facility. Among other things, this is hoped to enable PC formatted hard disks to be read (e.g. removable media) which will be helpful for software such as Discover. There are also changes to the map area. V1.51 contains an important change for Super-Hermes users, moving the store in battery backed RAM to another location for improved performance.

EZ-LITERATURE: This mammoth work of over 100MB of text files, including various classical literature and a huge collection of information about popular TV shows and films such as the X-Files, Star Trek and Quantum Leap was finally launched at the end of September. The final product includes useful utilities such as a file finder program and a complete drive copier (inclusive of subdirectories). Available on a single EZ-135 cartridge, price £25.00

AURORA: The much anticipated graphics card is now getting ever closer to launch. As we went to press, final testing of units with the required VRAM chips was taking place, with the production circuit boards to be ordered if trials were successful. Unfortunately, it looks as if the Auroras (or should that be Aurorae?) sent out will be somewhat lacking in software support for the enhanced colour modes, with the drivers being supplied on disk at a later date.

News from S.J.P.D. Software

SJPD have just received 20+ E/D disks of LineDesign Clip-art. They are all in _LDP format (Native LineDesign format) and so can be loaded directly into Linedesign. The size of some of the files is very large, the largest being 1,241,293 bytes! Since such files are too large for DSDD disks, Steve has decided to make this clipart available ONLY on ED disks! This selection adds to the already comprehensive collection of .AI format clipart for Line Design offered by SJPD.

Other disk releases from SJPD include a collection of Data Design utilities by Roy Wood and an address book for use with Archive on disk SJPD 64. Archivers Control Panel on disk SJPD is now INFO-ZIP compatible, while Zipback is a backup utility for owners of more than one hard disk drive, with backups being possible over a network. Also on SJPD65, 'STORE' allows users with Qubide and SuperHermes to store startup information in battery backed ram to bypass the startup delay with the Qubide system. V1.41 of the Qubide eeprom code is also included, so you can blow your own rom update if you have an EPROM programmer. Disk SJPD 66 includes issue 25 of the E-zine QL Hacker's Journal by Tim Swenson, a lottery syndicate number checker, a screen dump program for the Canon BJC range of bubblejet printers, and some zodiac sign clipart for Line Design.

Jonathan Hudson provides the content of SJS174, the PSUtils package, for reorganising Postscript files prior to printing with the Ghostscript package. SJS176, a three disk package, contains the entire DIY Toolkit collection from QL World, as written by Simon N. Goodwin. SJS175, meanwhile, contains John Miller's SBASIC PE Kit, as described in the last issue of QL Today. SJS177 contains a Qubide v1.51 ROM image, 2 pointer driven games from Germany, a front end program for the Ghostscript utility, another utility to allow the quick linking and unlinking of hard drive partitions, QFORMAT (a fast reformatting utility for floppy disks), and MEMV which displays a memory usage bar on the left hand side of the screen.

Meanwhile, for literature lovers, Steve Johnson has expanded his already wide range of classical book texts with further stories of Tarzan, classical science fiction from H. G. Wells and Jules Verne, and novels by Jack London. Disk CB65 contains the tales of Beatrix Potter for the younger QL users among us, while Doctor Who fans may be pleased to hear that a variety of information about the TV programmes is available on disk CB148. Finally, if your tastes include religion, CB156 (a 2 disk package) is "The Varieties of Religious Experience" by William James.

Finally, if you are a PC user, and want to go even further in improving it than just adding a QXL or QPC, Steve Johnson reminds me that he has a large range of software-based emulators for the PC, including almost all of Sir Clive's computers (ZX81, Spectrum and Z88). Steve can also supply emulators for (ah, nostalgia! - am I really this old?) the Oric, BBC Micro, Psion 3a, TRS80, Apple II, Apple Mac, CPC464, Sega, Atari 400/800 and Dragon computers. It seemed reasonable to include this information since we've given so much attention to emulators this month. From experi-

ence, I conclude that trying out many PC based software emulators will in the end only serve to point out how good a product like QPC really is (see the review elsewhere in this issue).

QPC Palettes: SJPD's catalogue contains on disk SJPD68 details of a utility for QPC users allowing you to set/read/reset the colour palette on a per-job basis. The software contains three extensions, implemented as an extensions "thing".

■

QL TODAY SURVEY

Dilwyn Jones

The number of survey forms returned was about 8% of the subscription base at the time. While this does not seem high, it is broadly in line with results for surveys of this type. Forms were returned from across Europe, Scandinavia, USA, New Zealand and even one from Iran.

The most requested software prizes were FiFi and QMenu. What was won, and by who, depended on Jochen's random number generator. In the end, the main prize was won by Lennart Forssen of Sweden, who chose QMenu.

Here are the average ratings for the subjects included in the survey. I had a little difficulty with some of the forms, as a few people did not use the suggested 0-6 rating system. If there was any doubt, I played safe and did not include those forms. The numbers given are the average for each subject.

Reports about QL shows	3.4
History etc of QL software houses	3.0
News in general	5.1
software news	5.2
hardware news	5.3
Software reviews	4.9
Hardware reviews	5.3
General hints on how to use software	4.7
General hints on how to fix problems	4.8
Tutorials on general programming	3.9
BASIC	3.1
Assembler	3.5
C	2.5
(there were also suggestions that we should have included Forth, Pascal and APL in this category)	
Do-it-yourself toolkits to be typed in	3.3
BASIC program listings to be typed in	3.3
Hardware related to the QL (e.g.printers)	4.3

Font size: almost 100% approval for this, with only one suggesting we should use a smaller font. One or two suggestions were received that we should also consider A5 format for QLToday. Magazine format: Stapled 39%, Punched 33%, Punched & Stapled 28%, Loose 0% (expected) Binders interest: No=70%, Yes=30%.

Since QL Today is published in European A4 size, and such binders are freely available at low cost in Europe, this is not surprising. It would be very expensive to ship binders out of Europe anyway, so I don't think Jochen will be buying any after this!

It is obvious that news about the QL in general is the single most liked part of QL Today. So we will do our best to bring you as much news as we can. Authors, traders, etc - please let us have all your news, our readers want to know about your products!

It was very encouraging that so many forms returned did not list any disliked articles! Good, but on the other hand, the most disliked articles were... (oh dear) my program listings in issue 2, Q-Draughts and PC versus QL, and Jochen's Epson Stylus Codes article. Closely following these in the unpopularity ratings were the DISA History, The Black Hole and EMC In England articles. The Black Hole and EMC articles did, however, get a respectable number of votes in the "liked articles" category too! Several people objected to the length of the BASIC program listings rather than the programs themselves, e.g. Dave Westbury said BASIC listings >20 lines may "put me off subscribing in future." Steve Papierowski of Manchester, England, suggested such listings should be split across issues. Since the magazine is only published every 2 months, I would not be too happy about that myself, and feel that Jochen's solution of making the listings available on BBS and via his PD disk service is the best compromise answer. There was even one suggestion that we include a cover disk with the listings on it, but Jochen has ruled this out on a cost basis, although he is looking at the possibility of a cover disk at the end of each volume containing the listings and an index to the volume, but possibly with a slightly reduced number of magazine pages to reduce the postage costs.

By far and away the most popular article was Jochen's My Boot article, so much so that I hope to run a short series of similar articles if I can find enough contributors. The next most popular articles were, surprisingly, the ones about the QPC emulator. I think Jochen will get even richer from this software!

The beginners' articles were liked and disliked by

similar numbers of people, for obvious reasons. Several readers commented that they couldn't believe that there were still QL users at this level, but there was plenty of advice to prove that there are. Harry Latham said that he often stopped reading a magazine when he saw words he didn't understand. Darren Branagh from Ireland said he appreciated the "excellent" beginners' articles. And John Dixon of London wanted "more on Word Processing - I don't understand computers".

The QL Rodents article (about QL mouse systems) was liked by many, and disliked by almost as many too. The Genealogy Bug, Buttons, QL Not For Profit, How We Produce QL Today and the software reviews were also well liked. The articles about the show in Bedford, USA, were seen as amusing by some, but disliked by many. However, we just couldn't displease John Miller of Hinton, England, who described QL Today as: "The Best QL Magazine Yet-Great!" Nice to know our efforts are appreciated - a warm thank you to all of the contributors who have helped make QL Today into a success story.

There were plenty of suggestions for articles to include in future issues too. P. H. Tanner wanted to see articles about Forth and Pascal programming. Michael Gruber in Berlin wanted to see more PD software reviews (good point, the QL is blessed with lots of PD software). Mats Averkvist in Sweden wanted "more build-it yourself hardware". John Hall in Aberdare, Wales wanted to see articles about the design of system software and using system resources. R.J. Shepherd in Exeter, England would like to see articles about Data Design, while Eleanor Patrick in Leeds, England, said she would like to see articles about getting difficult software to work on the QXL, as she has a few programs which she cannot get to run on her QXL system. Pedro Reina in Madrid, Spain wanted to know when QL Today will get an ISSN (International Subscription) number - how about it Jochen? *[Alread requested one, hope to have it for issue 5]* Several people wanted to see articles about Easypr. J. C. Marcus and Miguel Estarellas (both from Spain) wanted to see more DIY hardware hints. J.C. Marcus also wanted QL-related humorous articles. And finally, GH Alagheband in Teheran, Iran wished to see articles about fax modems on the QL.

So, do we have any volunteers to write about any of the above subjects? Contact me at the address/telephone/email details on page 2.

Thank you to everyone who responded, and especially to the people who sent letters in addition to the survey forms. I simply haven't got room for it all here!

■

Talk to Me!

Roy Wood

I was recently in the cinema with my fourteen year old son watching 'Independence Day'. Total rubbish of course, but quite enjoyable if you can do a 'RES_128' on your mind and just sit back and enjoy the spectacle. This, however, is not a Barry Norman style film review. My interest was sparked by a scene at the end of the movie when Jeff Goldblum saved the world by uploading a computer virus into the Alien's computer. There I was quietly relaxing in the cinema, sucking on my choc-ice, and my escapist peace was shattered.

Within a matter of a few hours Jeff Goldblum had written a virus, got into an alien spacecraft, flown up to the mothership and, using a notebook PC and some sort of radio link, logged on to a totally unknown system. 'Negotiating With the Host' - 'Connecting' - 'Uploading'! I had spent the last three days trying to get my Psion Series 3a to talk to my QL and I was using a cable! Should I give Jeff Goldblum a quick ring - the man was obviously a genius? I did, in fact, put up a couple of messages to Jonathan Hudson the QL's comms hero but this mainly reinforced my oft repeated maxim "The best way to find out what kind of a total idiot you are is to report a fault or a bug to an expert." As usual, nosooner had I pressed 'Y' on the bulletin board in response to the 'Save Message' query, the manual fell open on the page that told me what I was doing wrong. This is a normal phenomenon. It ranks along with the 'No matter how hard you look for something, as soon as you ask someone where it is you will find it in your pocket.' homily.

There has been a long running debate in Quanta about how to connect the two computers and it was, in fact, one of the last issues that came to my salvation. Thank you, Sven Weber, for your little table of connections which showed me where the problem lay. One little wire was all it was and ten minutes with a soldering iron put the wire in the right place. I am reproducing his table at the end of this piece (I hope he does not mind).

The thing that gets you banging your head firmly against the table top is that, even with this wire in

the wrong place, the two computers do communicate - sort of. When the Psion is plugged into the QL and the two are connected via the Comms software provided with the PSIWIN package (what an annoying thing - I had to buy Windows software that I will probably not use - Grrrr) and Jonathan Hudson's wonderful QTPI you can actually type on the Psion and have it appear on the QL and vice versa. This leads you to the totally erroneous conclusion that the connection is fine. And then you try to transfer a file. In actual fact you can transfer text files with the cable in the wrong place using the ASCII protocol - yes you guessed it, it was the handshaking that was wrong.

I therefore spent two and a half days setting and resetting the various protocol, baud rates, handshaking etc. I purchased a 9 - 25 pin D connector adaptor and plugged that into a standard Sinclair serial cable and thence into serial 1 - ah yes, that does not work at all now! I plug it into serial 3

from the equally wonderful superHermes, no go either. I retreat to the comfort of another glass of red wine. Later that night Jochen told me that not all of these adaptors are wired in the right way so that was the final straw that got me taking

the cables out of the box and firing up the multimeter.

As I said above the answer was in Sven's letter to Quanta and once the wire was in the right place transfers between the Psion on the QL were smooth. QTPI is very good for this purpose (and it's free!!!!) and you can save many different sets of settings for different purposes. I have two '_dist' files. QTPI_dist is the standard start up file that I use for the modem and is connected to the SER 3 port of SuperHermes. Psion_dist contains the settings for my Series 3a (see figure 1) and is connected to the SER 1 port. this arrangement saves all the scrabbling around at the rear of the QL tower case with cables.

I have used QTPI to transfer text, databases and spreadsheets although all of these need some fiddling before they will be usable on the QL. I have also successfully transferred some of the P.D.

Preferences	Commands F3	Abort	Quit
Emulation	ANSI4	VT KeyPad	Yes
Port	ser1	Job Swap	^C
Parity	None	Xon/Xoff	No
Flow	Handshake	Controls	Interpret
Translate	Raw Data	Exit Baud	9600
Baud	19200	Access	On Line
RX EOL	<CR/LF>	Scroll	5
TX EOL	<CR/LF>	Dial Try	4
Del Char	DEL (127)	Dial Wait	60
VT Wrap	On	Cmd Delay	0
XPR Protocol	YMODEM	Ser Buffer	16384
Beep	On	Start XPR	Full Screen
CSI	Interpret	On Wake	Redraw
Arrow Keys	As Keys	CR in log	Yes
7bit keys	No		
Comm Dev			

programs from S.J.P.D's collection of Psion software from a QL disk onto the Psion. Right now we are trying to get information on the Psion communications software to see if it is possible to get someone (we do have a volunteer) to write the kind of program that Psion uses on the PC. This software allows the user to interrogate the directory structure of the Psion from the other computer and move files without touching the Series 3 except to turn it on. Does anyone know anything about this? I would also be interested in anyone who would like to write some filters to make the Psion Database and Spreadsheet files importable into the QL programs (preferably QSpread and DATAdesign).

Well, my head has healed up now and there is only a dent in the kitchen table to show the results of my frustrations. I hope that this little piece will help you to avoid a similar headache.

Sven F. Weber's Cable guide for the Series 3a / QL Link:

3-Link	9-Pin D	Ser 1	Ser 2
1. DCD In	5.	1. Gnd	1. Black
2. RD In	3.	3. RxD	2. White
3. TD Out	2.	2. TxD	3. Green
4. DTR Out	6.		
5. SG Common	5.	1.	1.
6. DSR In	4.		
7. RTS Out	8.	4. DTR	5. Red
8. CTS In	7.	5. CTS	4. Blue
9. Ring	5.	1.	1.

As he says do not connect cable 6 on either of the QL SER plugs as these carry +12v. He also advises the Translates Menu to be set to 'Local Echo On', and I had the 'Protocol' set to 'YMODEM', the baud rate set at 19,200, 'Data Bits 8', 'Stop bits 1', 'Parity: None', and 'Ignore Parity: Yes'. The Quanta Article suffers from a misprint I believe because it gives the character '#' instead of '\$' The setting for the Enter Key should be '<\$0A><\$0D>' and the Backspace key '<\$7F>'.

A mouse cable will not work.

PGP (Pretty Good Privacy)

Tim Swenson

PGP is a Public Key Encryption program written by Phil Zimmerman, ported to the QL by Jonathan Hudson, and has become the standard encryption program for private citizens. PGP has

gained notariety and popularity over the last few years. Because of U.S. Export laws that treat encryption schemes as munitions, PGP has caused quite a stir in the computer and legal worlds. Phil Zimmerman had been under a Federal investigation to see if he broke export laws when PGP was distributed via the Internet. Some countries are not happy with the ordinary citizen having the capability of very secure encryption. Countries like encryption that they can break. This was demonstrated in the US with the introduction of the Clipper chip, where a federal agency keep the "backdoor keys" to everybodys secret keys.

Public Key Encryption Basics

Most people are familiar with what is known as private key encryption, that is, you use a password to encrypt data and use it again to decrypt the data. This all works fine except when you want someone to decrypt it. You must somehow send that person your private key, and still keep it private.

Public key encryption (PKE) is based on having two keys, one public and one private. If you encrypt with one key, say your private, you can only decrypt with the other key, your public. This allows you to publish one key and keep the other as a close guarded secret.

If you want to send a private message to a person and make sure that only that person to read it, you would encrypt the message in their public key. The only way to decrypt the message is to use the recievers private key, which means that only they could decrypt the message. This will also work to keep files private on your computer. Encrypt with your public key and only you can decrypt it.

If you want to put a digital signature on a message, you would encrypt it with your private key. Anyone decrypting it using your public key would know that only you could have encrypted it. There are also digital signatures that keep the text of the message in the clear, but guarantees the text will go unchanged.

UnZipping PGP

PGP version 2.3 (589K zipped) and 2.6 (688K zipped) have both been ported to the QL. This article is based on 2.6. To unzip PGP26_ZIP you will need a ED disk. I tried to unzip to HD but I ran out of disk space. If you don't have an ED disk drive, you should be able to specify which files you want unzipped with UNZIP. The program unzips with two hard subdirectories (a la Gold Card). I don't know how it will unzip if your QL does not support hard subdirectories.

Professional & Graphical Software

Amelia Iowan Old Style **BREMEN BOLD** Kuenstler 480 ∞ΔΓαβ Goudy Handtooled
 Caslon Oper Revival 565 **PROforma fontpack** Staccato 555
 Shelley Alley Venetian 30. Calligraphi **agull Bold** Iel Gothic
 Carmina **Old Italic** **Allegro**
 Old Droadfal No.7 Goudy Old Style Freeform 721 Dom Casual Amerigo Carmina Italic

ProWesS

ProWesS is a new user environment for the QL. ProWesS is short for "PROGS Window Manager", but it is much more than that. Apart from a new window manager, it contains all the system extensions from PROGS, and is essential if you want to run programs which need these extensions. The ProWesS reader is a major part of the package. It is a hypertext document browser. This means that text files which include formatting commands (including pictures) and possibly links to other files can be displayed and read in this program. This is used in ProWesS to read (and possibly print) the manuals, and display the help files. The hypertext documents which are used by the ProWesS reader are in HTML format, the format which is popular on Internet to display World Wide Web pages. Another important aspect of ProWesS is the possibility to allow programs to automatically install themselves on your system, and to be able to run them without resetting the system. This means that, when you get a new program, all you have to do is insert the disk and indicate "start the program in flp1", a menu option in the "utilities" button. To install a program, you indicate "install software", and the software can be added to your system. This way, you don't need to know how to write a boot file to use the multi-tasking capabilities of your computer. ProWesS includes many programming libraries. These include syslib, an interface to the operating system, PROforma, a vector graphics system, allowing rendering both on screen and on paper (via a printer driver). The DATAdesign engine is also part of ProWesS. It is a relational database system with a bonus, as you don't even need a key field. You get a powerful record at a time data manipulation extension to the language you already use. Of course it also includes ProWesS itself, the new resolution independent window manager.

DATAdesign

Never before has it been so easy to create, fill in and maintain your personal databases. To start a new file, just type the names of the fields. To add or delete a field, no problem, just do it. To change the name of a field, just indicate it. What's more you can choose to look at only those fields you want, and in any order you specify. And you can select which records you want to view, and which not. DATAdesign allows you to have some hidden comments for each record, have a general look at the file (in tabulated form) or to transfer a record into the scrap of hotkey buffer, so you can easily import a record in your favorite text processor or editor! Security is a strong point for DATAdesign. Usually files will be memory based, for maximum speed. Files can also be disk based, making sure all changes are immediately stored on disk, so even in the event of power failure, you can at most lose the changes to one record! Naturally, DATAdesign is good at sorting and searching. And if you were using another database, you can convert Archive or Flashback files to DATAdesign. The new v4 of DATAdesign makes the program even easier to use than before. You can now also have QD-style icons on your screen to make the program even easier to operate.

PFlist

Easy to use program to create listings on any printer (especially inkjet and laser). This ProWesS application allows you to indicate the files which have to be printed. Each column contains a footer which can include the filename and filedate. The listings always allow perforation. PFlist can create your listings in two columns and in landscape (or both).

All our software has electronic manuals, which can be read and printed in the ProWesS reader. However, we can also supply printed copies of the documentation (or even your own HTML files). The costs are BEF 2 per page, plus postage costs. Contact us for more details. ProWesS does not include the programming documentation. This is available via bulletin board and public domain software suppliers. The programming documentation is readable in the ProWesS reader, and partly in DATAdesign (the demo version is included). We can supply the programming docs for BEF 100 (HD disks only!) If ordered with something else, you don't have to pay extra postage.

ProWesS - BEF 2400 DATAdesign - BEF 1200 fontpack - BEF 3000 PFlist - BEF 600

Payment terms :

You have to run ProWesS to make DATAdesign and PFlist work (even though DATAdesign uses wman).

All our software is normally supplied on high density (HD) disks. However they can be obtained on double density (DD) disks at an extra cost of BEF 100. To use ProWesS and any of our other packages, you need a system with at least 2MB of memory. You should have a second disk drive, or a harddisk (recommended). The use of SMSQ/E is strongly recommended for optimal use of ProWesS.

If you are VAT registered (specify registration number) or live outside the EEC, the amount to be paid is the total (including postage) divided by 1.21 (no need to pay too much).

Payment can be done by EuroCheque in BEF, or by VISA, EuroCard or MasterCard. Credit card orders can be handled by phone. For credit card, please specify name of card owner, card number and expiry date.

Postage : Costs of postage and packaging have to be added. You can choose the quality. Rate depends on no of programs.

copies	priority mail			ordinary mail		
	Belgium	Europe	World	Belgium	Europe	World
one	100	200	230	100	120	135
two	110	340	420	110	180	215
3 or 4	120	560	770	120	300	370
5 to 8	160	870	1250	160	550	675
more	200	1130	1610	200	800	1005

All prices are in BEF, including 21% VAT

Haachtstraat 92, 3020 Veltem; Belgium, tel/fax (016) 48 89 52

The key files are PGP and PUBRING_PGP. The rest of the files are supporting documentation and source code. Once you create your own public and private keys, other files will be created.

Using PGP

PGP has been directly ported from the MS-DOS or Unix version, and they are very command line driven. There is not nice front end to PGP for the QL. You will need to have TKII to use command line arguments. When running PGP you will run it like this:

```
exec pgp; "-xx"
```

where -xx is one of the many command line options.

The advantages of directly porting to the QL are:

1. Once you learn PGP on the QL, you already know it for MS-DOS and UNIX. Of course this also works the other way. If you have learned PGP using MS-DOS or UNIX, you know how to use it on the QL.

2. All prompts and program information is exactly the same as the MS-DOS and UNIX versions. Any books or articles showing PGP screens will work for the QL.

In fact, there is a book for PGP. It is "PGP: Pretty Good Privacy" written by Simson Garfinkel and published by O'Reilly and Associates. It is THE book for PGP, it's use and history. Since my office had a copy of the book, I used it to learn how to use PGP on the QL.

Creating Your Own Keys

Once you unzip PGP you will first want to create your own public and private key set. This is done using the -kg option.

```
exec pgp; "-kg"
```

Once a window pops up with some initial information, you will get to choose what type of PGP key you want. You can have a 512-bits (less secure but fast), 768-bit (medium speed, good security), and 1024-bits (highest security but slow). I choose 512 bits, primarily because I had nothing much to hide and I wanted something fast.

You then get to type in a user id for your public key. When you give your public key, this is how you want your name to go with it. The documentation suggests your name plus an e-mail address. So, I went with "Timothy C. Swenson <swensont@mail.serve.com>."

Next you are prompted to hit keys so that PGP can generate 624 random numbers. Just hit some keys until you see the number count down to 0. If you hit too many, don't worry. If you see a question

mark pop up it just means that you hit the keys too fast.

Now the program will generate your public and private keys. On a Gold Card this took about 4-5 minutes. On a regular QL, this may take a while. Once the program is done, your two keys are written to disk.

Managing PGP Keys

Before I go into how to encrypt with PGP I want to talk about how to manage PGP keys. When you created your own set of keys, PGP saved the keys to two files; SECRING_PGP and PUBRING_PGP. PGP keeps all keys in rings (key rings, get it?). Each ring is just a binary file that stores all of the keys. Typically the file SECRING_PGP will only contain your secret key (because you really should not know somebody else's) and PUBRING_PGP will contain your public key plus any public keys you wish to add.

PGP uses a number of command line options (all beginning with -k) that let you manage keys. To get a summary of these options execute PGP with just a -k option and it will list all of them. A few of the important ones are:

- kv View public keys in PUBRING_PGP

- kg Generate your own keys (we just did that).

- ka Add a key to either ring.

- kr Remove a key from either ring.

- ke Edit your User ID or Pass Phrase (password).

- kx Extract a copy of your public key from the public key ring.

To show how some of this works, lets extract your public key from your public key ring so that you can give it to somebody. You do this by using the -kx option:

```
exec pgp; "-kx swenson tswenson"
```

This will extract the public key with the ID of "swenson" and put it in the file "tswenson_pgp". Now I can give this file to anybody. Remember that this file is still a binary file. If you want to extract an ASCII version use the -kxa option. This makes it easy to send via e-mail.

Now lets say we are somebody else and we want to add "my" public key to our key ring. We can do this using the -ka option. We can add either binary or ASCII public keys with this option.

```
exec pgp; "-ka tswenson_pgp"
```

This adds the public key in the file "tswenson_pgp" to the current public key ring (PUBRING_PGP). If we have a specific name for our public key ring (say one for each department of a company) we would add the name of that file right after the name of the incoming file.

Encrypting with PGP

Now comes the core of the program, encrypting files. You can encrypt files for keeping or for sending secure messages. The difference is who the recipient is, since you will be encrypting the file/message with the recipient's public key. If you are encrypting for yourself, you are the recipient. If you are sending the file via e-mail or disk, then the other person is the recipient. Either way the command line is the same:

```
exec pgp;"-e file.txt recipient"
```

where file.txt is the file you want to encrypt and recipient is who is going to get the file. If it was encrypting a message for myself the command line would be:

```
exec pgp;"-e file.txt swenson"
```

Since the resulting file will can be a binary file, using the -eat option will make sure that the end encrypted file is in pure ASCII so that it can be sent via e-mail.

Decrypting with PGP

Now that you've encrypted a file, let's figure out how to decrypt it. PGP does not require any command line options for decrypting files. And since it is assumed that you will be decrypting files encrypted with our public key, PGP knows to decrypt with your secret key.

```
exec pgp;"file.txt"
```

This tells PGP to decrypt the file file.txt. PGP looks up your secret key in your secret key ring. PGP can trust that file, but it does not trust who executed it. You will need to enter your pass phrase (password) to let PGP know that you are who you say you are. This keeps other people from trying to decrypt your files on your computer.

Digital Signatures

Digitally signing your files is nothing more than encrypting a file with your secret key. Then when a person decrypts the file successfully with your public key, they know that you encrypted it. In PGP, this is altered slightly. When you sign a file, a small PGP signature section is added to a file and it acts as your signature. The rest of the file is left un-encrypted. When signing a file, you do have the option of encrypting it.

To sign a text message, you exec PGP like this,

```
exec pgp;"-sta file.txt"
```

You will need to supply your pass phrase to sign the file. The resulting file will be called file.asc. The -S option is for signing, the T tells PGP that the input is a text file, and the A tells PGP to make the output file ASCII.

To verify a digital signature, exec PGP like this,

```
exec pgp;"file.asc"
```

PGP will work through the file and see the digital signature section and verify the digital signature. If any change is made to the file after it was signed, the verify will come back as invalid. A form of checksum is done on the file to make sure that any changes to the file will be noticed.

Conclusion

PGP give the QL user military-level encryption. Anything you encrypt is going to be safe. I have not yet found a need for encrypting any of my data, but if I ever do, it is nice to know that PGP is there. But I can see a use for my using digital signatures. Since computer text is so easy to fake. Posting a document to the Internet means that anybody can alter it and pass it along as yours. Adding a few key "not"s can really alter the meaning of a statement. Having a digital signature on the document will foil any attempt to forge or spoof something I've written. This may not be important now, but if I am going to post something as my "official" word on something, having the digital signature give a greater level of confidence in not having the message altered.

This article has only scratched the surface of what PGP can do. Read the PGP documentation or pick up a copy of the PGP book to learn more about the full capabilities of PGP.



Di-ren's Internet

Robin Barker, Di-ren

Many readers may consider articles regarding the Internet as "so much waste of space" because as yet, the QL has no real net capability. Whilst it is true a substantial number of QL users do not have access to the net, a surprising number do! Via different machines maybe, but they are still QL enthusiasts.

It may interest you to know the Di-Ren Web site records at least 150 hits (accesses) to its QL section every week. This number can vary dramatically. Last week for instance there were 352 hits. The highest ever total back in April 1996 was 473. I cannot determine "who" has accessed the site, simply that somebody has. It is quite possible not all visitors are QL users - so much the better!

In my opinion the Internet has two very useful features. Firstly it provides a somewhat disjointed, but massive information database; and secondly, a means of transmitting messages world-wide. Email, frankly, is wonderful! I can send and receive

half a dozen messages world-wide in less than 60 seconds, at the cost of a local telephone call. This has dramatically cut my telephone bill. On the down side however, it is all too easy to bump up the bill again just browsing the Internet!

There is a wealth of information available on the net, and a lot of rubbish. Most new users go through a steep learning curve. It doesn't take long to realise you must access or search for specific information! Just "surfing" the net can be time consuming, horribly expensive in telephone charges, and reveal nothing of any interest at all.

Some Internet critics point to bulletin boards as a better option. Like all things in life there are for's and against's. Although users accessing bulletin boards do not have to pay an Internet Service providers monthly fee (from £6.00 upwards), accessing a German BBS by telephone, from say, America is not cheap either. Additionally you do not have the benefits of Email. From the BBS provider's point of view things are slightly different. To make available information on the Web, you have to rent space on a Web file server. Although not particularly expensive nowadays, it may still be cheaper to install a BBS dedicated telephone line if you have more than a few megabytes of files to make available. One thing BBS's cannot enjoy however, is the potential audience of millions linked up to the Internet.

The QL has surprisingly good coverage on the net. Meetings information, product updates, electronic catalogues etc, etc. You can even download a JS ROM disassembly. Most Web sites have pointers to other sites with similar interests. Take Bruce Nicholls' Quo Vadis Design. This has pointers to other QL resources, including the Di-Ren site. Conversely, the Di-Ren site has pointers to the QUO Vadis site, and so on.

Information as mentioned before is much and varied. This is what you would find on the Di-ren QL section:

Meetings information, Traders details, Other QL Internet resource lists, the IQLR document, QUBBESoft's Web page including the Aurora graphics card detail sheet, Details of QL magazines including QL Today, QUANTA and Update magazines, SJPD's Web page and electronic catalogue, Di-Ren Products (of course), A QL users Email address database, QL sales and wants, etc, etc. It is even possible to download Amadeus System files and demonstration versions of Fleet Tactical Command II!

Remember this is just one Web site. The combined information and resources of all the QL related sites is quite staggering. Other useful information is also available. For example, Hewlett

Packard have a site from which can be download all sorts of information, including printer instruction sets.

It is sometimes the case that users only have partial access to the net. A common situation is Email facilities only. Whilst it is possible to obtain Internet documents via Email with the aid of specialised servers, this can sometimes be difficult and slow. To make life easier for QL'ers in this situation, Di-Ren have programmed an Automatic Email file retrieval utility. Operation is quite simple.

Simply send an Email addressed to forms@di-ren.demon.co.uk. The body of the document should contain the command "AUTO SENDFILE" and the file name required. For example "AUTO SENDFILE ql/homepage.htm" would command the handler to return the file "homepage.htm" found in the "ql" subdirectory on the Di-Ren Site. "AUTO SENDFILE help.txt" returns the "help" file, the contents of which explain how to retrieve documents (pointless really as you will have already done it to get the help document!)

Judging by the number of "orders" for files since being introduced, this is obviously a popular service.

The handler actually runs on a QL. In fact, all automated processes run on a QL linked to the PC responsible for Internet operations. The reason as usual is the QL's programming simplicity and versatility.

Internet "Newsgroups" are an interesting phenomenon. Something like BBS's, people post ideas and discuss problems etc. As is always the case in this type of arena, there are those who operate their mouths (or fingers perhaps!) before putting the brain into gear! I fell foul of some adolescent diatribe a short time ago after making a posting mistake. It was amazing to see how many self appointed gods and half wits came out of the woodwork. Tony Firshman (bless his little cotton socks) came to my defence, as did others - thanks team!

I have made a point of not cluttering up this article with Internet addresses and pointers. If you load "<http://www.di-ren.co.uk/ql/homepage.htm>" on Web browser software, pointers to other QL resources are there!

Meanwhile, if it is still summer when you read this - make the most of it - "cos it ain't gonna last"!

Robin Barker Di-Ren

support@di-ren.demon.co.uk

STOP PRESS: Since this article was written, Di-Ren's eMail address has changed, see the news on page 4!

■

TF SERVICES

MINERVA

The ORIGINAL system upgrade

MINERVA RTC (MKII) + battery for 256 bytes ram, CRASHPROOF clock & I²C bus for interfacing. Can autoboot from battery backed ram. Quick start-up.

OTHER FEATURES COMMON TO ALL VERSIONS
DEBUGGED operating system / autoboot on reset or power failure / Multiple Basic / faster scheduler-graphics (with 10% of Lightning)-string handling / WHEN ERROR / 2nd screen / TRACE / non-English keyboard drivers / "warm" fast reset. V1.97 with split OUTPUT baud rates (+ Hermes) & built in Multibasic.

1st upgrade free. Otherwise send £3 (+£5 for manual if required). Send SAE, Minerva + disk/3 mdvs.

MKI..£41 (£40) [£43] RTC(MKII)..£66 (£63) [£76]

GOLD CARD (incl. SUPER) compatible

superHermes

A major hardware upgrade for the QL now ready and shipping

- All Hermes features (see below for list) PLUS full 19200 throughput not affected by sound
- IBM AT keyboard interface (for UK/US/Germany)
- HIGH SPEED RS232 two-way serial port, ie 5000cps throughput (supergoldcard/qtpi zmodem) at 57600bps
- THREE low speed RS232 inputs (1200 to 30bps). Driver for SERIAL MOUSE supplied. Other uses - RTTY/graphics tablet etc.
- THREE spare i/o lines (TTL) with GND/+5v
- Capslock /scrollock LED connector
- Turbo/keylock connectors
- 1.5k user data storeable in EEPROM

All this on a professional board about twice the size of the 8049 coprocessor it replaces

Cost (including manual/software)£92 (£87) [£90]
 IBM AT Keyboard (acer)£24 (£23) [£27]
 Serial mouse£13 (£12) [£14]
 Capslock/scrollock led (+wire&plug)£1.50 (£1) [£1.50]
 Keyboard or mouse lead£3.50 (£3) [£3.50]
 High speed serial (ser3) lead£4.50 (£4) [£4.50]

Specify PANEL MOUNTING or IN-LINE

QL SPARES

Keyboard membrane£12.50 (£12) [£13.50]
 Circuit diagrams£3.50 (£3) [£4] 68008 cpu£8.50 (£8) [£11]
 8049 IPC£8.50 (£7.50) [£9] Serial lead£11.50 (£11) [£12]
 1377 PAL£3.50 (£3) [£4]
 Power Supply (by sea)£17 (£16) [£21]
 8301, 8302 or JM rom set£10.50 (£10) [£11]

Other components (sockets etc.) please phone

I²C Interfaces

Connects to Minerva MKII or any Philips I²C bus
Parallel Interface gives 16 input/output lines. Can be used for logic level output eg model train controllers. Input direct to motor drivers (eg L293/L298)£26 (£24) [£27]
Analogue Interface Each gives 8 analogue to digital inputs, and 2 digital/analogue outputs. For temp measurement, sound sampling etc.£31.50 [£29] [£32]
Data sheets (analogue/parallel)£2.50 (£2) [£3]
Control software/manual (Superbasic extns) £2.50 (£2) [£3]
 (First interface purchase includes free 15D/9D lead)

QL REPAIRS

Fixed price for unmodified QLs, excl. microdrives. QLs tested with Thorn-EMI rig and ROM software.

£27 including 6 month guarantee (UK)

QBBS - UKs first QL scrolling Bulletin Board

Megabytes of files. Messages to/from UK/Belgium/Holland/USA/Italy/Germany for a UK phonecall. TANDATA callers add SIX zeros (000000) or wait for 3 seconds of modem tone if dialling manually.

01344-890987 (up to V32bis)

TF Service now on the Internet!

E-mail: tony@firshman.demon.co.uk

<http://www.firshman.demon.co.uk>

COMPUTER CLEANER

High Spec AC mains filters and spike removers

All in standard 3-pin devices and are plug-in
NO WIRING REQUIRED. In their 10th year of production - as old as the Sinclair QL.

2-way adaptor ... £14 3-way adaptor ... £18

4-way trailing socket £24 (all UK prices)

Prices incl. AIRMAIL postage & packing. Prices are EC except UK (Europe outside EC) [outside Europe] unless stated otherwise. Ring for UK prices or see Quanta. Payment by Mastercard/Visa/Access/Eurocard/cheque/postal order or CASH. MAIL ORDER ONLY - no callers without ringing first. Send IRC for full list and details.



Holly Corner, Priory Road, ASCOT, Berks, SL5 8RL

TEL. 01344-890986 FAX & BBS: 01344-890987



QL Service List - Part 3

Robert Klein

Again, here comes the next part of the QL Service List. If we have missed somebody in one of the first parts and he/she feels that he/she should have been in one first parts, then please let us know and we will publish up-to-date information in the next issue.

Clubs

The following Club list is alphabetically ordered. I only added the contact address.

Austria:

DER Computer Club
c/o Peter Postl
Stieberg 5
A-5110 Wien

Belgium:

Club Sinclair BruQsl
c/o Jaques Tasset
Aarlenstraat 104
B-1040 Brussels

QL Club
c/o Leon Thianche
Rue Paul Wemaere 12-14
B-1150 Bruxelles

France:

QL Contact France
c/o Jean-Louis Dianoux
22 Avenue Lenine
F-93230 Romainville

Germany:

Sinclair QL User Club e.V.
c/o H.P. Recktenwald
Albestr. 21
D-12159 Berlin

Greece:

QL Athens Club
c/o Stathis Grigoriadis
Tarsu 6-8
GR-10440 Athens

The Netherlands:

Sin_QL_Air
c/o Marco Holmer
J P Coenstraat
NL-3531 EN Utrecht
magazine: Quasar

Italy:

QItaly Club
c/o Roberto Orlandi
Via Brescia 26
I-25039 Traveglianto (BS)
magazine: QItaly magazine
Editor: Dr. Eros Forenzi
Via Valeriana 44
I-23010 Berbenno (SO)
Tel. +39 - 342 / 590 450
Fax +39 - 342 / 590 451

Norway:

Norwegian All Sinclair Assosiation (NASA)
c/o P Monstad
Sondenalia 27
N-4200 Sauda
magazine: Sinclair Magazine

Scotland:

Scottish QL Users Group
c/o Alan Pemberton
65 Lingerwood Road
Newtongrange
Midlothian EH22 4QQ
Great Britain
(they have a newsletter)

Spain:

Qliper
c/o Marcos Cruz
Acacias 44
(Monteclaro)
E-28233 Pozuelo de Alarcon
magazine: Qliper

Sweden:

Svenska QL-Gruppen
c/o Johan Boman
Toftaasgatan 73
S-42147 Vastra Frolunda
magazine: QL-Bladet

Jamten-TCL (International QL echomail conferences)

BBS +46 - 63 - 133 330
Michael Cronsten
Radhusgatan 61E
S-83137 Ostersund
Sweden

Turkey:

QL Club

c/o Bul9ent Artuz
Prof. Sitesi B/1 D/5
Etiler 80600
Istanbul
Turkey

United Kingdom:

Quanta (UK) Membership Secretary

c/o Bill Newell
213 Manor Road
Benfleet
Essex SS7 4JD
Great Britain
phone: (01268) 754 407

magazine: Quanta

Editor: Phil Jones
66 Devonshire Ave.
Long Eaton
Nottingham NG10 2EP
Tel: 01159 730 142
Great Britain

Ashtead sub-group

c/o Anthony Gordon
13 Beales Road
Great Bookham
Surrey KT23 4NA
Great Britain

Bristol sub-group

c/o Roy Brereton
94 Teignmouth Road
Clevedon
Avon BS21 6DR
Great Britain

East Anglia

c/o Geraint Jones
1 Bridgate Court
Thetford IP24 3AJ
Great Britain

Essex sub-group

c/o Dave Walker
22 Kempton's Mead
Potters Bar
Herts EM6 3HZ
Great Britain

London sub-group

c/o Basil Lee
31 Fairdale Gardens
London SW15 5JW
phone: 0181 789 1976

or email Martin Wheatley at
martinw@mail.bogo.co.uk

c/o Jeremy Davis
6 Elmcroft Crescent
Harrow
Middx HA2 6HN
Great Britain

North-East

c/o Derek Stewart
20 Emily Street
Gateshead
Great Britain

Northern Ireland

c/o Billy Turkington
Fairy Hill
Rostrevor
Newry
Co. Down
BT34 3BB
Great Britain

Mid-Southern sub-group

c/o Geoff Fish
44 Billing Avenue
Wokingham
Berks RG11 4JE
Great Britain

QL User Group (West Midlands)

c/o Mike Bedford-White
16 Westfield Road
Acocks Green
Birmingham B27 7TL

QL MUG (Merseyside)

c/o G Reynolds
0151 / 932 1484
(fortnightly meetings)

Solent sub-group
c/o Graham Evans
32 Reeves Way
Lowford
Bursledon
Southampton
Great Britain
Tel.: 01701 / 403 350

USA:

**New England Sinclair QL User Group
(NESQLUG)**
c/o Sherm Waterman
P.O. Box 8763
Boston MA 02114
USA
magazine: NESQLUG
Editor: Peter Hale
195 Central Ave
Chelsea
MA 02150
USA

The Menu Extension (QMENU) - Part 2

Dilwyn Jones

The LIST_SELECT menu is altogether more advanced, allows more options and requires an understanding of how to use arrays from Superbasic. It was not available in very early versions of QMenu, so if you have bought a very old copy it may be worth upgrading just to get this very useful menu. LIST_SELECT has a tremendous number of options available and this may make it seem difficult to use. True, at first you may have to experiment a bit to see what each variation does. Using the menus is not that difficult, but trying to remember all the parameter values for all the possible facilities is more difficult (frankly, even after years of using it, I still have to look at the manual every time I use QMenu). After a few years of using the menu extension, I still have to look at the manual to check the order of parameters, values for flags and so on. The best way to write programs with QMenu is to have the manual open close to hand, you may never remember from memory what each value does!

LIST_SELECT is used for choosing options in a

list or program menu. The list is held in a string array and the item or items chosen from the menu are actually choices of strings from the array. It is often used as the 'main menu' of a program. It is much more versatile than ITEM_SELECT, not just in the number of items which can be selected, but also in the options and features which may be specified. There is some control over layout and appearance, plus an option to allow multiple items to be selected, or an immediate return once any item has been HIT or DOne. The list of items should be placed in a string array before calling the LIST_SELECT menu. You should also prepare a numeric array containing the status bytes unless you want the return immediately after any item has been selected. First, we'll look at an example of this simpler option.

The following program displays a menu from which you can choose one of a number of options. It might be suitable as a menu for a quiz program, where you are invited to choose a subject. Note how the list is built into a string array (str\$) and how only the name of this array is required in the LIST_SELECT command - no need to specify the array subscripts or brackets.

```
100 REMark LIST_SELECT example 1
110 CLS : DIM str$(3,10)
120 LET str$(0) = 'HISTORY'
130 LET str$(1) = 'GEOGRAPHY'
140 LET str$(2) = 'MUSIC'
150 LET str$(3) = 'SCIENCE'
160 LET item = LIST_SELECT('SUBJECT',
str$,,1+16,4,10,,,0,1)
170 SElect ON item
180   =-1 : PRINT'ESC pressed.'
190   =-2 : PRINT'OK chosen.'
200   =0 TO 3 : PRINT'You chose the
subject ';str$(item)
210 END SElect
```

Figure 5 shows what this menu looks like.

We omit the 'status' item to force the menu to return as soon as you HIT or DO on any of the items. This includes the 'ESC' and 'OK' items either side of the menu heading. What use you make of those items is up to you. ESC is normally used to quit from the menu or program, while OK can have a variety of uses, especially when using the multiple HIT version of this

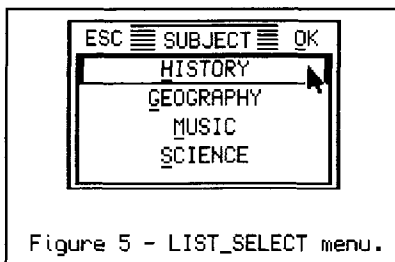
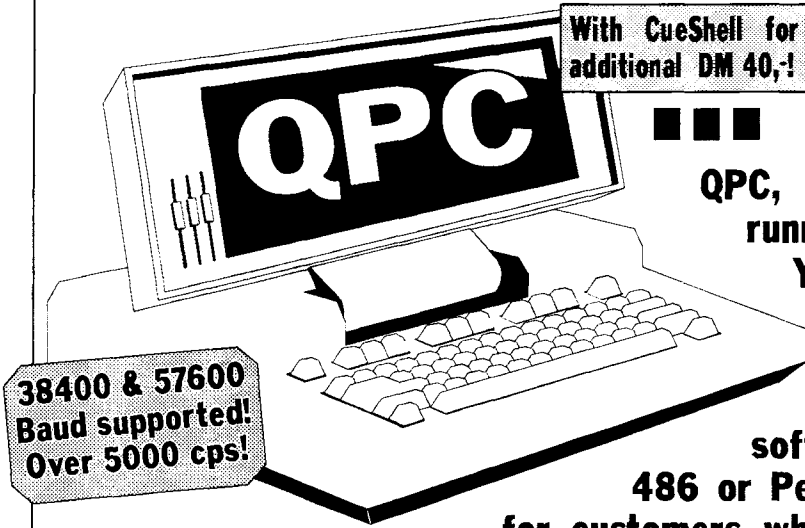

Figure 5 - LIST_SELECT menu.

command. I sometimes use the OK item as a command to redraw a program's display where

JOGHLEN MERZ SOFTWARE

Im stillen Winkel 12 • 47169 Duisburg • Germany
 ☎ 0203-502011 (Fax 0203-502012 Mailbox 0203-502013 & 502014)



is here!

QPC, the brandnew QL-Emulator running SMSQ/E is ready now! You can now run SMSQ/E on PC's and even Laptops without extra emulator hardware - it is emulated in software! Minimum requirement: 486 or Pentium. The price is DM 199,- for customers who already own SMSQ/E for other systems, otherwise it will be DM 249,-. You can order NOW!!!

QL Games

- BlackKnight Chess . . . DM 119,90
- Pipes DM 29,90
- BrainSmasher DM 39,90
- Arcanoid DM 39,90
- Firebirds DM 39,90
- QShang DM 39,90
- Diamonds DM 39,90
- The Oracle DM 39,90
- MineField DM 39,90
- Double Block DM 39,90
- The Lonely Joker 2 . . . DM 59,-
- SuperGamesPack DM 90,-

QL SPARES

- ZX8301 DM 24,90
- ZX8302 DM 19,90
- Keyboard membrane . . DM 25,-
- QUBIDE Harddisk 1/F . . DM 199,-

QL Applications

- QD Editor [V8.15] . . . DM 125,-
- Fifi II File Finder **NEW!!!** [V4.01] . . **DM 49,90**
- QMAKE [V4.13] . . . DM 44,90
- QLiberator SuperBASIC Compiler DM 139,-
- QLoad-Ref DM 49,90
- QLQ [V1.13] . . . DM 69,90
- QMAC Macro Assembler [V1.01] . . . DM 69,-
- QMENU [V6.29] . . . DM 39,90
- QPAC 1 [V1.05] . . . DM 61,50
- QPAC 2 [V1.37] . . . DM 119,-
- QTYP 2 Spell-Checker [V2.17] . . . DM 82,50
- QPTR Pointer Toolkit [V0.28] . . . DM 89,90
- QSpread Spreadsheet [V1.31] . . . DM 169,-
- QSUP [V3.08] . . . DM 79,90
- EPROM Manager [V3.01] . . . DM 61,50
- WINED [V1.18] . . . DM 49,90
- I/O 2 Toolkit [V2.15] . . . DM 99,-

QL Applications

- LDUMP [V1.04] . . . DM 65,-
- DISA Intelligent Disassembler [V3] **NEW!!!** . . . DM 95,-
- DISA V3 - Upgrade from V1 or V2 **DM 35,-**
- EasyPTR Part 1 DM 89,-
- EasyPTR Part 2 DM 49,-
- EasyPTR Part 3 DM 49,-
- DataDesign Database DM 149,-
- DataDesign API DM 59,-
- LineDesign Vektor/DesktopPublishing DM 239,-
- Fontpack for LineDesign DM 195,-
- Pfdata DM 59,-
- Stylus-Driver for text87 and text91 DM 69,-
- ProWesS WindowManager + HTML Reader DM 119,-
- HyperHelp for BASIC DM 44,90
- DiskMate 5 DM 69,-
- CueShell DM 95,-
- QDOS/SMS Reference Manual DM 84,90
- BASIC Linker **NEW!!!** DM 49,90**

← PRICE CUT PRICE CUT PRICE CUT PRICE CUT

SMSQ/E For all Systems V2.77

SMSQ/E is the new operating system which allows you to run your QL programs and adds an enormous amount of additional features: faster, flexible disk format, multiple and much faster BASICs, faster screen driver and much more!

- For QXL & QXL 2 DM 199,-
- For ATARIs with QL-Emulator DM 199,-
- For ATARIs without QL-Emulator DM 249,-
- For GoldCard & SuperGoldCard DM 199,-

NEW! QXL2!

QXL2 card with 8MB RAM and the "extended" Version of SMSQ, called SMSQ/E (see left) for only **DM 749,-** or, without SMSQ/E, only **DM 629,-**

TERMS OF PAYMENT

Postage and package [Germany] DM 8,80 (if total value of goods is up to DM 50,- then only DM 5,80). [Europe] DM 14,- (if total value of goods is up to DM 50,- then only DM 9,-). [Overseas] between DM 14,- (1 item) and DM 35,- (maximum). All prices incl.

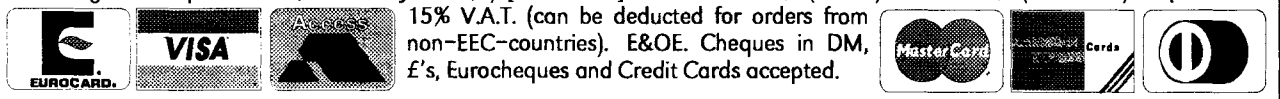

15% V.A.T. (can be deducted for orders from non-EEC-countries). E&OE. Cheques in DM, £'s, Eurocheques and Credit Cards accepted.

that facility is required (like SHIFT F5 in Quill). The value 17 (shown as 1+16 in the listing to show how it is made up) means: 1 causes the menu to underscore the first character of each item, and to use that letter as the selection key for the menu item (luckily, all the items have names starting with different letters!), while 16 causes each menu item to be centred horizontally within the menus. An additional possibility, which would be useful if two or more items started with the same character, is to add a 4 to this value to force the menu to add an underlined character before each item, usually allocated in alphabetical order, e.g. A-History, B-Geography and so on. This can be centred too, so you would calculate the value for this parameter as 4 (put keystroke before items) + 16 (centre items), total 20.

The next two parameters, 4 and 10, specify the maximum number of lines and columns respectively. There are 4 items in the menu, so 4 lines is a good choice. You can have some fun here changing the 4 to a smaller or higher value and watching what happens. The menu will either change shape to fit in the items as best as it can, or it will now introduce scroll bars. What this means is that a few of the items are shown, but you can scroll up or down to see the rest of them with a HIT or DO on the arrows which appear. In practice, this is unlikely to happen with a small menu like this, but for larger lists (such as lists of files on a disk), there may well be too many to fit on the display, so the menu will be forced to use scroll bars.

The next two parameters were omitted (note: I included the commas, but put nothing between them). These are for the menu position, so the menu is drawn at the current pointer position, or as close as possible when the pointer is at the edge of the screen.

The final two values in the parameter list are the colourways. This menu can have two separate colourways, one for the body of the menu itself, and the second for the items in the list. Here, I used the 0 to specify that the menu itself is to be drawn in white and green, while the list colour scheme is 1 (black and red).

Many parameters in these menu commands can be omitted or default values used. The QMenu manual shows these in square brackets, so it is quite easy to know what can be omitted.

In that first menu, we omitted the status parameter (the third one) so as to only allow one item to be selected. By adding a one dimensional numeric array as this parameter, we can give each item a separate status. Apart from allowing the user to select any number of parameters from the list, this allows us to specify, for example, which items in the list are available (e.g. a list of all files on a disk, but only Superbasic programs can be selected). The available and unavailable items are shown in different colours. Also, items you HIT will be shown in a different colour. There are four states you can impose on each item in the list - available, unavailable, selected and editable (the latter in more recent versions of QMenu only). To work out the status value of each item, you use these values: 0 = available 128 = selected 16 = unavailable 16384 = can be edited. Some of the values can be added together, e.g. if the item concerned is available and can be edited, add 0 and 16384. Some of the conditions cannot be used together - e.g. an item cannot be unavailable and yet can be edited! This facility is one of the more complex features of this menu, and a fair deal of practise and familiarisation is required to acquaint yourself with what is possible.

When you DO on an item, or you HIT or DO on either the ESC or OK items, the menu returns. This is when it gets interesting. You can now examine the status array to see what the user selected, whether anything was edited and so on. This facility is really useful, but only if you are sufficiently familiar with the use of LIST_SELECT. I will give here a listing which shows how to make use of it, but it may not make sense until you actually use it, so if you haven't already bought it, buy it now (somehow, can't you sense that I like the software?). What the program does is to read all the filenames off the disk in FLP1_, puts them in an array and invites you to select a few filenames. After playing with it for a bit, HIT or DO on OK and the program lists what you did.

```

100 REMark LIST_SELECT example 2, needs ramdisk
110 CLS
120 OPEN_NEW #3,RAM1_TEMP_FILE : DIR #3,FLP1_ : CLOSE #3
130 OPEN_IN #3,RAM1_TEMP_FILE : INPUT #3,t$ : INPUT #3,t$
140 nfiles% = 0 : REMark count of number of files first time round
150 REPEAT loop
160 IF EOF(#3) THEN EXIT loop
170 INPUT #3,t$ : REMark a filename
180 nfiles% = nfiles% + 1

```

```

190 END REPEAT loop
200 CLOSE #3 : OPEN_IN #3, RAM1_TEMP_FILE : REMark now read into array
210 DIM str$(nfiles%-1,36), status%(nfiles%-1)
220 INPUT #3, t$ : INPUT #3, t$ : REMark skip past medium name etc
230 FOR a = 0 TO nfiles%-1 : INPUT #3, str$(a) : REMark filenames
240 CLOSE #3 : DELETE RAM1_TEMP_FILE : REMark tidy up after use
250 REMark set status for all filenames to 'available' and 'editable'
260 FOR a = 0 TO nfiles% - 1 : status%(a) = 16384+0
270 LET item = LIST_SELECT('SUBJECT', str$, status%, 4, 10, 10, 0, 0, 0, 1)
280 SELECT ON item
290   =-1 : PRINT 'Oh, you indicated "ESC"! '
300   =REMAINDER : REMark anything else, list the files
310     PRINT 'You selected the following files.'
320     LET sels% = 0 : REMark number of files selected
330     LET edits% = 0 : REMark number of filenames edited
340     FOR a = 0 TO nfiles% - 1
350       IF status%(a) && 128 THEN
360         PRINT str$(a); : sels% = sels% + 1
370         REMark was the entry edited?
380         IF status%(a) && 256 THEN
390           PRINT ' (was edited).' : edits% = edits% + 1
400         ELSE
410           PRINT
420         END IF
430       END IF
440     END FOR a
450     PRINT 'Total number of filenames selected was '; sels%
460     PRINT 'including '; edits%; ' edited.'
470 END SELECT

```

The various permutations available in this menu will probably give you a headache at first; but persist - it is an extremely flexible menu with a lot of uses. Don't worry too much if you can't get the 'editable' values to work, they are not used much.

The Character Select menu is a fairly recent addition to QMenu and allows the user to select a single character out of a list of characters. A classic application for this would be in a font editor program. You could even get

the menu to display the edited characters by supplying the menu with the address of a font table (standard QDOS font format), but the default is the standard built in font. Using a font table allows correct display of edited characters. I have used this menu with an IBM PC standard character font, which allows me to do simple graphics (e.g.

rectangles and shadows) with the line and shading characters in those fonts. You can specify which characters from the font are to be available by supplying an availability byte with various bits masked as shown below:

- 0=whole character set shown
- 1=non-printable characters
- 2=number characters 0-9
- 4=lower case characters
- 8=upper case characters
- 16=remaining printable characters
- 64=cursor control characters

These values can be combined, so if you want just letters and numbers, the value becomes $8+4+2=14$. The syntax of the command is shown in the next listing, which creates a menu allowing you to select a letter or a number only. Figure 7 shows

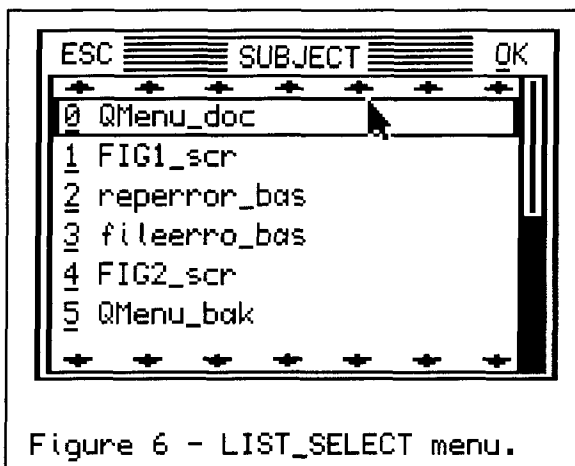
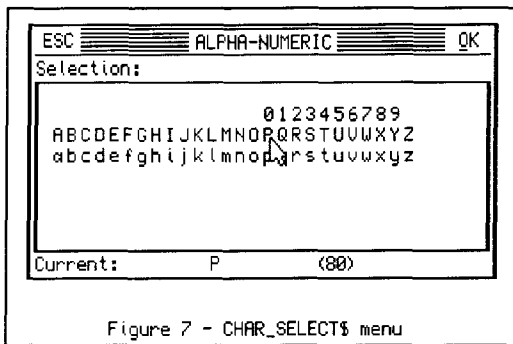

Figure 6 - LIST_SELECT menu.

what the menu looks like. There is one little anomaly to mention here. You will notice that a parameter is missing between the $2+4+8$ and the '0' used to specify the character set. The command does not work without this extra parameter and there is no information in the manual as to what it does - perhaps it is meant to allow for a future facility to be added to the menu.

```
10 LET t$ = CHAR_SELECT$( 'ALPHA-NUMERIC
',2+4+8,,0,50,50,0,0)
```



Before we progress to the file handling menus, there is one other facility I would like to touch upon. QPac2 users will be familiar with the 'button frame'. A button is an on-screen little box with the name (usually!) of a program, that program can be selected by a DO on the box. QMenu offers this facility, to put your program into a button for you. The `BUTTON_WAIT` command allows you to specify a name or text to use in the button. Position and colour can optionally be specified. The manual states that a "job may not have any open windows, otherwise correct positioning of the button cannot be guaranteed". If the QPAC2 button frame is present, the button will usually go there - buttons usually work best in association with the button frame.

QL Serial Ports

H.-Peter Recktenwald

I've done a lot of testing with the serial ports since I'm working on a terminal program and found out that those ports are by far not as bad as is usually believed. The most frequent and undetected error source seems not to be the bad hardware construction, but the bad quality of its components, where a major overhaul might cure many problems.

Thus let me report on some details I'd discovered (or re-discovered) during error checking and monitoring the hardware proceedings of the QL serial data link - which is rather a technical matter and not another view on protocols and software control.

A warning in advance: The QL is powered up for all measurements mentioned and the components involved are very sensitive and might react immediately to a short-out or any other accidental false connection, so the proceedings

should be carried out very cautiously! You do all this at your own risk! Any mistake could dispense with the life of the components at once, and yours too!

The implementation of SER1 and SER2 is as "full duplex" serial ports with the minimum of signalling to facilitate some hardware handshaking.

Full duplex operating has been monitored with an oscilloscope, thus it definitely takes place and it works properly as it was intended to, but with the low speed of the QL it would come into effect only with low transmission speeds. Despite considerably slowing down the process due to the port's design it was also working error free in a standard QL, with the simple (old) Gold Card fitted, with a simultaneously open channel to the other SER port connected to a printer.

The one and only real thing which is wrong with those QL ports seems to be the misleading labelling of the DTR line which, in truth is more like the RTS of the RS232 description. Not exactly, but it should be used as if it were.

Also misleading might be some defective hardware component if the service routines of the QL still (pretend to) work properly, which happens quite often. Then one might be able to communicate with the hardware protocol set but in reality just because those routines work so well even with no handshake at all (found and tested at rates of up to 4800 baud). Most commonly the user doesn't suspect those partly defective components to be the reason for the QL's bad serial ports data exchange. It seems to promote the concept that those parts fail completely, or never. Both of which are not true.

In fact, those components are driven so near overload that this kind of damage could happen quite often. Not easy to detect because rarely, virtually never, a component fails completely and at once, the programs then just report a high error rate.

The tests referred to were carried out with SER2 connected to the COM2 port of a PC by a "nul modem" cord. The results can be applied to SER1 by exchanging what refers to TXD with RXD and RTS with CTS. I'd note "DTR" in double quotes for the QL name of the signal which appears to work like the fairly standard RTS.

As a safe point to start from these are the relevant V.24 (RS232) signals as defined by the different documents (CCITT V.24, DIN 66020, EIA RS232):

P.O. Box 7
Portslade
East Sussex
BN41 2ND

Tel. 01273-386030
Fax 01273-381577

Q Branch

Feeling out on a limb?
Reach out for Q Branch
Suppliers of Quality QDOS / SMSQware

A Merry
Christmas
And a

Happy
New
Year

To all our customers

Why not get some
new programs
for

your
directory
tree?

Or put a BOOT file on
your Xmas stocking.

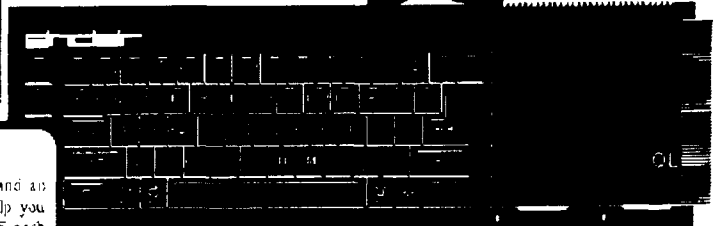

The Demo Disk Collection.

We have demo disks of many of the programs mentioned here and an informative catalogue which describes many of them in detail to help you decide if a particular program meets your needs. The disks cost £1.25 each - 30p P&P and the catalogue is free if you send a stamped addressed A5 envelope.

If you buy a copy of Cueshell or DM 5 from us we will include a free disk with FileInfo 2 and the Archivers Control Panel - two P.D programs from Theiry Godefroy which greatly aid the use of the file handling programs.

If you buy Easypointer we will include a free disk with the Pointer Environment Kit on it. This is a series of articles and examples in BASIC which make using EASY pointer much easier.

If you want to know more call us on the numbers above or leave us a message on the BBS (Roy Wood or Steve Hall).

Watch this space for other news and offers from Q Branch.

ARCADE GAMES

Arcanoids	£ 17.00
Firebirds	£ 17.00
Diamonds	£ 17.00
Doubleblock	£ 20.00
S. Games Pack	£ 40.00

P. E. GAMES

LonelyJoker 2	£ 28.00
The Gracie	£ 24.00
QShang	£ 22.00
Bob's Pipes	£ 20.00
Minerfield	£ 19.00
Black Knight	£ 55.00
Brain Smasher	£ 20.00

UTILITIES

FFI - the file finder	£ 24.00
QPAC 1 - Utilities	£ 20.00
QPAC 2 - The P.E. utility	£ 40.00
QSUP	£ 36.00
QTPY 2 - Spellchecker	£ 30.00
Cueshell 2 - File Utilities	£ 40.00
Disk Mate 5 - File Utilities	£ 37.00
QSpread - spreadsheet	£ 77.00
Qleak - Archive accounts	£ 25.00
Printed manual for above	£ 20.00
DBEasy - Archive progs	£ 18.00
DBProgs - Archive progs	£ 14.00
DATAdesign - database	£ 32.00
PFdata - better printing	£ 24.00
from DATAdesign	£ 24.00

PROGRAMMING

QD 8 text editor	£ 58.00
QBASIC basic parser	£ 21.00
QLIBERATOR compiler	£ 50.00
QD + QBASIC	£ 75.00
QD + QBASIC + QLIB	£ 120.00
SPY text editor	£ 15.00
MASTER SPY text editor	£ 30.00
QPTR pointer toolkit	£ 42.00
EASYPTR part 1 Base	£ 40.00
EASYPTR part 2 Sbasic	£ 20.00
EASYPTR part 3 C	£ 20.00
QMake - Assembler	£ 21.00
QMenu - pointer menus	£ 20.00
QMon / JMon	£ 44.00
DISA 2 - disassembler	£ 40.00

SMSQ/E

For the following systems:

Gold / Super Gold Card	£ 90.00
QXL	£ 90.00
Aran	
(without QJlump C.D.or	
E level drivers)	£ 90.00
Incl drivers	£ 112.00
Monochrome version	£ 134.00
All three systems	£ 180.00

QPC

now available :

SMSQ/E owners	£ 95.00
non - SMSQ/E owners	£ 120.00

PROGS - ProWesS

ProWesS - windowing system	£ 50.00
PFlist (new version)	£ 14.00
PF fontpack (new price)	£ 65.00
LINEdesign - the drawing program	
that made this advert	£ 100.00

File Search
(new ProWesS product)
£ 14.00

OTHER STUFF and NEWS

Books

Archive Made Easy (book and disk)	£ 20.00
QDOS / SMSQ reference manual	£ 38.00

We are now stocking the BASIC LINKER program.
A new pointer driven linker for Super Basic programmers.
only £ 24.00

Also new this month is the PROGS File Search program
running under ProWesS.

This product is only £ 14.00

PFlist is also now running under ProWesS and there is a
special price reduction on the PF fontpack £ 65.00

The GEOFF WICKS COLLECTION

We stock the three programs in the Geoff Wicks collection of lexicography programs: Thesaurus, Solvit 2 and Style Checker. They are available separately at £ 15.00 each or in the following formats.

Q1 Words (Solvit and Thesaurus)	£ 25.00
Q1 Writers Pack (Thesaurus and Style Check)	£ 25.00
Lexicographers suite (All three programs)	£ 35.00

EXTRAS

SERmouse	software cable and black mouse	£ 40.00
I/O toolkit	see Quanta (Sept 96) for details	£ 46.00
Mailmerge	Archive based program from ARK	£ 10.00
Mailfile	Mailist database from ARK	£ 35.00
Pheonix	File resurrection from ARK	£ 8.00

0 = Signal-Output, i = Signal-Input

Computer (x of QL)			Null-Modem Partner
1	x,1	protective Ground	1
2	0 TXD x	Transmit Data	3
3	i RXD x	Receive Data	2
4	0 RTS (x)	Request to Send (sender has data to send)	5
5	i CTS x	Clear to Send (partner ready to receive)	4
6	i DSR	Dataset ready (electrically enabled)	20
7	GND x,1	Signal Ground	7
8	i DCD	Data Carrier Detected (peripheral receives carrier) - open -	
20	0 DTR (x)	Data Terminal ready (sender enabled)	6
22	i RNG	Receiving a Line Call	- open -

(x) the QL-"DTR" works as the RTS-Signal, therefore the V.24-DTR should be connected to the QL's +12V (pin 6).

1 pin 1 since 1976 is no longer a defined CCITT signal.

The connections while testing have been:

QL SER2	25-Pin-Adapter or Modem	PC, 25-Pin Null-Modem
GND 1	1, 7	GND 1, 7
TXD 2	2	TXD - RXD 3
RXD 3	3	RXD - TXD 2
"DTR" 4	4	RTS - CTS 5
CTS 5	5	CTS - RTS 4
+12V 6	20	DTR - DSR 6

As you see on the above tables it would make no sense at all connecting pins 6 to 20 on the same connector. That way the equipment would just tell itself its own state of being enabled or not. Which usually should not lead to any problems, except, that most (low cost) equipment does not behave in a way defined by the standard(s). The worst case could be the unit enabling itself to send but disabling any reception afterwards, or the opposite.

The SER2 connection may be interpreted:

RXD Receiving input.

TXD Transmitting output.

DTR" Functionally the RTS signal, enabling the peripheral to send.

CTS Receiving the enabling signal to transmit own data.

+12V Used to simulate the true DTR, signalling the peripheral that it is connected to an electrically activated device.

Thus the "handshake" protocol on the QL works out to alternately enabling the connected units to sending their data. The fact of being connected and active, implied (at the QL side) and signalled

to the partner by the constantly high level carrying (true) DTR line.

Signal levels:

Logic 0 is represented by high level and logic 1 is represented by low level in the ranges of 3V to 15V, the gap of +/- 3V being reserved for service purposes only. The QL's signal levels are +12V and -12V, respectively.

The "QL Service Manual" gives a very short and incomplete description which I will, therefore, dispense with. It says that the interface was designed for "full duplex" mode (re above) and the data is transmitted in an eleven bit frame, one start bit, eight data bits and two stop bits while the receiver demands at least one stop bit to be sent with the exception that at 9200 baud, one and a half stop bits are required. It also says what was just discovered on behalf of the standard description and the monitored signals, that the handshaking is maintained not by a pair of "handshake" lines, but working with two equally evaluated signals of opposite directions, instead.

The signal traces of SER1 and SER2, each:

TXD	SER1 #2 -> 1489 #10	- 1489 #8	- via o.C. NAND to 8749 #6/21
	ULA2 #14 -> 1488 #4/#5	- 1488 #6	- SER2 #2
RXD	ULA2 #13 -> 1488 #2	- 1488 #3	- SER1 #3
	SER2 #3 -> 1489 #13	- 1489 #11	- via o.C. NAND to 8749 #6/#21
CTS	8749 #35 -> 1488 #9/#10	- 1488 #8	- SER1 #5
	SER2 #5 -> 1489 #4	- 1489 #6	- ULA2 #7
DTR"	SER1 #4 -> 1489 #1	- 1489 #3	- ULA2 #6
	8749 #36 -> 1488 #12/#13	- 1488 #11	- SER2 #4

The "DTR"-levels, channel(s) open, no data transfer taking place:

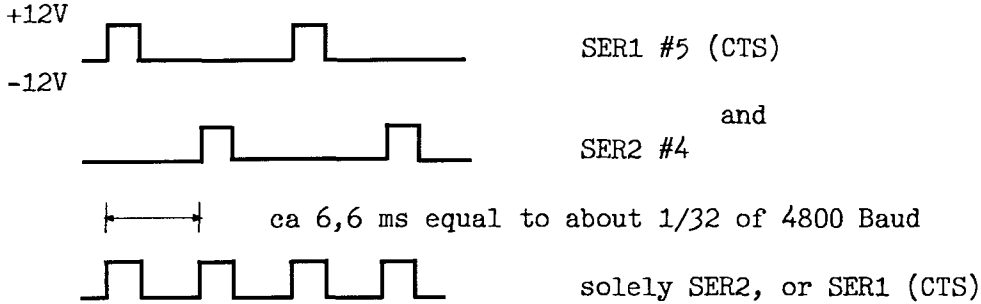

Transmission control by "DTR":

"DTR" starts with low level. After a channel was opened to the port it starts sending pulses of +/-12V at a 32th of the current baud rate. At times of high level the port is ready for receiving and if receiving that signal remains high, interrupted by single disabling pulses at a period of about 60ms (measured at 4800 baud).

By the way, the sound generator also locks the receiver.

Receiving and sending time intervals are each 1/4 of the pulse period, the intermediate pause times being left for other purposes of the QL. Closing the SER channels sets the corresponding "DTR" (ser2) or CTS (ser1) back to constant low level.

Most tests hve been carried out with handshaking disabled. This proved to be surprisingly reliable (which is one reason for not discovering defective hardware components) and even with many more transmission errors worked out to be faster than the handshake protocol. The latter of which is the consequence of the "DTR" handshaking pulse duration usually not coinciding with the request, leading the control programs to wait until a leading edge is detected, and the transmission being interrupted at the above mentioned intermediate pause times every 60th millisecond.

Some hints on hardware repair:

The facts mentioned up to now will help to find and analyze a possible hardware defect. Success depends greatly on the partner equipment working in a known and predictable way - and on the

availability of an oscilloscope, without which analysis of the pulse signals would be very difficult. You also will depend on having the QL circuit diagram or, at least, on having the data sheets of the components concerned, which you anyway would need.

The first step should always be taking any seemingly relevant measurements and write them down for later analysis. Sudden actions on one item found to be the odd one out might easily lead to wrong and probably even worse "repairs", so, keep calm and collect as much of information as possible before doing any hardware related repair.

At least, without an oscilloscope, any voltmeter would do, preferably one of the more old-fashioned non-digital ones, because of the inner resistance being sufficiently low to not picking up surrounding noise signals - if you get an uncertain display on a hi-tech-instrument try to bridge its inputs with a resistor of about 100k. If the display still shows different values, that would be a sign of the component tested being completely non functional.

First, a measurement should be taken of the supplies of the 1488 and 1489A components and the quiescent levels at the SER pins, each one, and noted down. At this time the outputs should constantly remain on low level, at about -12V. Any level below would imply a defective voltage regulator and no further tests should be carried out until that one was replaced. Any other supply level not within tolerances also should be treated with the appropriate repair before taking further actions on checking the SER hardware.

The -12V regulator will be found near the NET connectors and one of the fixing screws at the rear right hand side of the printed circuit board, and should be replaced with the next "stronger" model, a type 7912. The original low power ones are easily driven to such a high load that they start oscillating, which easily leads to self destruction, mostly resulting in an internal short-circuit of input and output. The output then would reach a level of about -18V, over-driving the connected components and at some stage destroying them, and, further, possibly even damaging the next following components connected to any(!) pin of those ones, and so forth.

To protect against line noise and oscillations of the regulator, the input should be buffered with a 330nF capacitor, connected to ground level immediately near the leads of the integrated circuit, and the output with 100nF to ground.

If the supplies are within tolerances open a channel to SER2 and proceed.

From now on the "DTR" signals should show the pulse sequence mentioned. This signal is most easily misinterpreted, the QL very often appearing to work properly, in a non-handshake manner, regardless of the channel's mode, if internal malfunctions take place, while the other i/o faults are easy to detect.

Therefore that signal needs special attention and will be discussed here.

If these pulses are completely missing, and the measured voltage found to be at a level above -10V, one of the SER output integrated circuits (of type 1488) channel is completely non functional.

With open (interrupted) outputs a resistor of 1k connected to a supply line would lead the zero output voltage to be drawn considerably near the supply level. Thus if a formerly 0V output can be pulled in this way to about +/- 10V this component certainly is broken down and needs to be replaced.

If the "DTR" output remains near low (negative!) level while the 1488 proved functional, that can be a sign of the 8302-ULA being damaged. The output concerned of that IC would then carry a constant level of above +3V due to some internal connections disrupted.

Also the co-processor itself might be damaged, the outputs of which are nearly as sensible as those of the ULAs, and behave the same, i.e. mostly carrying a constant level near +5V if an output is damaged.

Other constant "DTR" levels can be due to a defective 1488 transmitter IC which react sensibly on line peaks, and sometimes even pass those peaks through to the 8302, imposing a further and

possibly final load, then overloading that due to its own breakdown.

Another common source of malfunction is the IC not properly inserted into its carrier. For a quick fix just pull them out and push them back to be safe, and ensure that no pin was bent aside, or under the ic body, which easily remains undetected. Sometimes the IC seems to working even with a bent pin, as it could possibly get sufficient supply current to the inner circuit via an input.

Line disturbance:

On the mains supply lines very short (about 10ns) high tense glitches up to about 10kV have been monitored, produced by (old) electro-motive equipment, or even neon lamps. Those pulses damage any silicon electric components due to their high input impedance. There is only one way to protect: That is shortcutting those pulses, as they proceed not really "through" electric connections, but will be guided by them. The capacity of 2pF between two ic pins appears to be no isolation to those signals.

The diagrams below reflect some factory recommendations as to suppressing those glitches from outside:

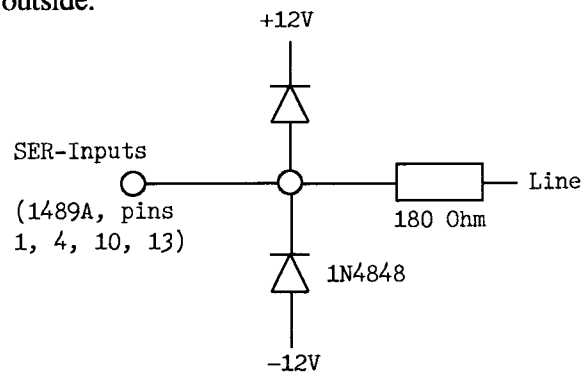

A resistor in line with the input will rarely minimize the receiving capabilities, but could sometimes prove quite protective. And with the diodes fitted some extra resistance is mandatory anyway to enable that protection. Just try it.

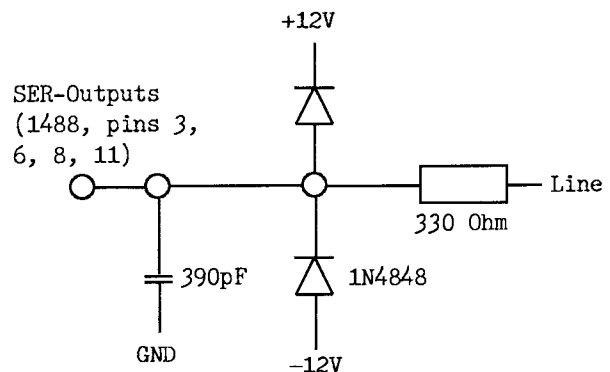

SINCLAIR

Z88

OFFICE/FAX 01494-871319 (EEC) *W.N. Richardson & Co.*

MOBILE: 0850 597650

6 Ravensmead
Chalfont-St-Peter
Buckinghamshire SL9 0NB

THE IDEAL PORTABLE COMPANION FOR THE QL

THE CAMBRIDGE Z88 A4 NOTEBOOK

WITH BUILT-IN WORD PROCESSOR, SPREADSHEET, DATABASE, BASIC, CALCULATOR, CLOCK, ALARM, CALENDAR & VT52 TERMINAL.
USES 4XAA ALKALINE CELLS (ca. 20 HOURS) *

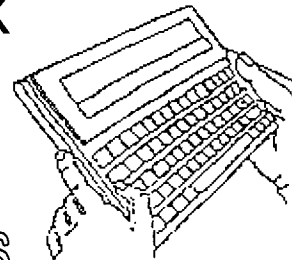

WE DO REPAIRS, PART EXCHANGES, AND WILL BUY Z88'S & PARTS

ALL UK PRICES INCLUDE VAT.

DESCRIPTION	UK	USA
CAMBRIDGE Z88 COMPUTER	£99	\$130
32k RAMPACK	£18	\$25
128k RAMPACK	£38	\$50
512k RAMPACK	£80	\$100
1Meg RAMPACK	£160	\$200
32k EPROM PACK	£18	\$25
128k EPROM PACK	£24	\$33
256k EPROM PACK	£55	\$75
EPROM ERASER	£32	\$43
PARALLEL PRINTER LEAD	£39	\$50
SERIAL PRINTER LEAD	£12	\$16
* MAINS ADAPTOR (230vac; 6v,500ma)	£10	\$20
TOPPER (PROTECTIVE COVER)	£12	\$16
CARRYING CASE (PLASTIC)	£10	\$12
'Z88 MAGIC' A BETTER USER HANDBOOK	£15	\$20
FILE TRANSFER TO OTHER COMPUTERS		
SPECIAL Z88-QL SERIAL LEAD	£10	\$15
COPY DISKS OF QUANTA PROGS IMP/EXP & ARCHVIE EXPORT	£2	\$3
PCLINK KIT (For PCs)	£25	\$35
Z88 TO MAC KIT	£25	\$35
Z88 TO BBC KIT	£25	\$35

20% OFF
Special discount for
QL Today subscribers
off Z88 parts,
QLs, 2MB & 4MB
Floppy Disk Drives
till Dec. 31st

UK PRICES INCLUDE VAT; USA PRICES DO NOT. FOR OTHER NON-EEC COUNTRIES DEDUCT 10% FROM THE UK PRICES.

POSTAGE UK £5. EEC £15. USA £20. OTHER COUNTRIES £30.

ALL THE STOCK IS WARRANTIED FOR 90 DAYS. IN THE EVENT OF REPLACEMENT BEING ARGREED, BUT THE ITEM BEING OUT OF STOCK AT THE TIME, A REFUND WILL BE MADE PROVIDED THE ITEM IS RECEIVED IN GOOD CONDITION.

QL & PC COMPUTER USERS WILL FIND THE CAMBRIDGE Z88 ESPECIALLY USEFUL FOR WORK AWAY FROM THE DESKTOP, WITH TRANSFER PROGS DATA CAN BE SAFELY EXCHANGED WITH THEIR DESKTOP SYSTEM.

W.N.RICHARDSON & CO CONTINUES TO PROVIDE FULL SPARES AND SERVICES FOR SINCLAIR COMPUTERS, QL & THE CAMBRIDGE Z88

The diodes shortcut most energy from over voltage glitches (transient suppressors would be even better - and more expensive), the R/C combination integrating the remainder, and also smoothing too high slewing rates (that is a measure of the speed of the voltage changing levels), which can cause signal reflections, resulting in non-readable data.

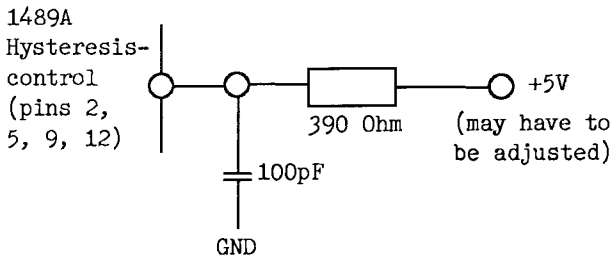

Summary:

As I (I hope) made clear, many seemingly harmless faults might occur with the SER hardware, ending up with those ports becoming non functional or, worse, partially functional which in many cases may remain undetected.

If that hardware is in a properly working state, the QL's SER ports work reliably and conform to what the (pseudo) standards require.

If you suspect some software bug, mainly after monitoring many transmission errors on formerly good lines, you should test the hardware components, as in many cases the defective ones seem to work, which in fact they don't.

Anyway, and even with no suspected malfunction at all, a general checkup seems highly recommendable: Not even one of my own (five) QLs, collected from new in the cheap selling phase of the QL, turned out to be fitted with fully functional hardware components. This included an undetected defective co-processor disabling one SER port's handshaking facility.

Q-emuLator, QL on the Mac

Al Boehm, Bedford, USA

As I write this review in Quill, my son is driving me back from vacation. I am able to do this since I have a Mac Laptop PowerBook with a QL emulator. I have a Gold Card QL, two QXLs, a Thor XVI (which is broken, lightning hit it!), so why should I get a Mac? The answer for me is simple; my job requires it. But since a lot of my work is in SuperBasic (or Sbasic), I was glad to learn in a NESQLUG meeting that there was a QL emulator for the Mac.

The Q-emuLator is a software only emulator that more or less does everything a Super Gold Card does, but on a Mac computer. It was written by Daniele Terdina, a student in Trieste, Italy. It comes in two versions. Version 1 for 68k Macs (the 68k means a Mac that uses a Motorola 68000 series CPU just like the QL, (S)Gold Card, and the QXL.) Version 2 is for PowerMacs which use a RISC CPU.

My Mac PowerBook 5300cs uses a 100MHz RISC CPU, so when I first tried Q-emuLator version 1 back in March everything ran slow, slow, slooow. But in April, version 2 came. Things ran much faster; in some cases (see below) rivaling the speed of the QXL!

QL Windows Within A Mac Window

When you start the Q-emuLator, two Mac windows appear. The first starts with a picture of a QL and when clicked by the mouse becomes a duplicate of the QL initial screen with Press F1 for monitor etc. When F1 is pressed, the default QL #0, #1, and #2 windows are displayed within this first Mac window. However, if there is a boot in MDV1_ (See next paragraph.) then that boot will load and run.

The second Mac window shows a replica of two Microdrives in a case complete with little red lights that light when the drive is in use. Now there are no Microdrives on a Mac. These are "virtual" Microdrives" that are really icons that allow the name MDV1_ or MDV2_ to be attached to a floppy drive or one of the Mac Folders (directories) on the hard disk. These virtual Microdrives can be renamed FLP, WIN, etc. thus are quite versatile. MDV1 can be attached to a floppy drive and renamed FLP1 so that when your program tries to read FLP1 it actually reads the floppy drive.

Also available are eight RAM Disk drives. There is a method of fooling the virtual drives into thinking they are reading a microdrive. Thus some of the copy protected microdrive programs which check for a coded number can be ported to floppy disk or even to the hard disk and still run.

Actually there is a third Mac window. This is the tool strip at the top of drop down menus. These control Q-emuLator and set a variety of defaults. For example, under Display one can select Proportional (circles are circles) or No double lines (each Mac pixel is a QL pixel). Under Keyboard there is QL mode, Mac mode, and Raw mode. The RAM menu sets the size allotted for Q-emuLator: 128K, 384K, 640K, 1M, 2M, 3M, or 4M. The QL menu can turn sound on or off (nice touch), set default directories, switch ser1 and ser2 (baud up to

19200), skip the picture of the QL when starting, and other defaults.

The Frequency menu sets the screen refresh rate, the Speed menu can slow down Q-emuLator for games, and the Window menu selects the QL or Microdrive windows.

QDOS or Minerva

Because of copyright limitations, QDOS does not come with Q-emuLator. Clear instructions are given on how to copy QDOS from your QL rom and install it on Q-emuLator. Minerva could be used but not SMSQ/E (Jochen, hint!). Other add-on roms such as TK2 can also be installed on the Q-emuLator.

Once QDOS is installed, the Q-emuLator runs programs much like any other QL. I have tried quite a few games, other QL programs, and a lot of SuperBasic; all have run without a glitch. Daniele found only three programs (they were games) incompatible out of a total of 129 tested.

Mac Interaction

The Q-emulator is multi-tasking on the MAC which allows for some very interesting interaction. Mac hard disk files can be directly accessed and

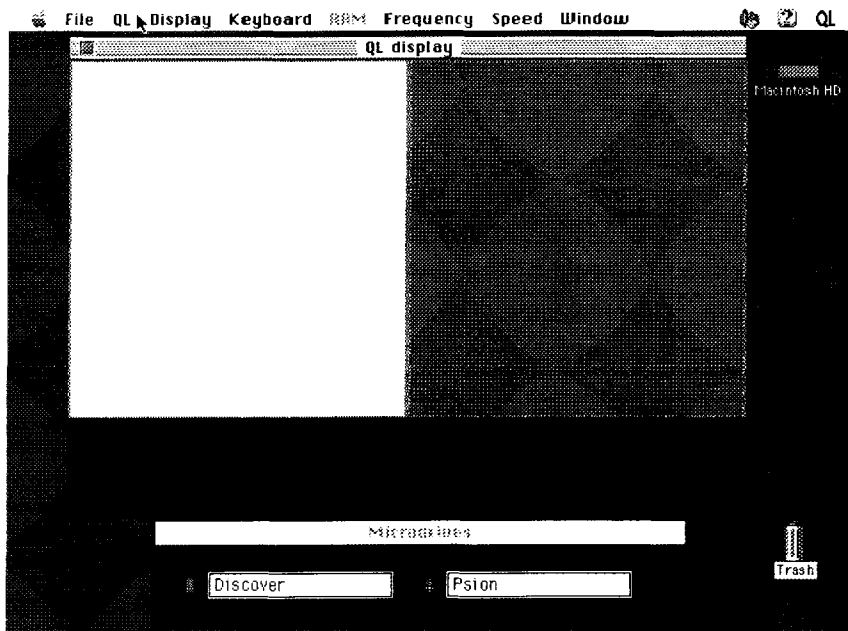

the Mac can work directly with the Q-emuLator files. With PC Exchange installed on the Mac, Q-emuLator can read QL, PC, and Mac floppies. However, the manual warns that some disks formatted with some of the older disk drives may not work with the Mac disk driver due to hardware

differences. So far I have only come across one disk that my QL could read but the Q-emuLator could not. Further, I had another disk that the Q-emuLator could read but the QXL could not!

Q-EmuLator comes with BBedit Lite, a Mac freeware editor, which handles the line returns of QL, PC, or Mac files correctly and also allows reading of the HELP files prior to installing QDOS. Thus I haven't needed on the Q-emuLator some QL programs such as QD (editor) and FiFi (file finder) which are invaluable on the QXL.

SPEED

Since the Q-emuLator is multi-tasking, its speed depends a lot on what the Mac is doing. This is not a simple case of not running any Mac program to get max speed. The Mac is designed with a lot of graphics in the interface. There are a host of Mac extensions that do neat things but take a slice of time. The Q-emuLator Manual points out some things that can be done to optimize speed. For example, the Q-emuLator runs noticeably faster if the mouse pointer is not kept on the QL window. Thus the times that follow have to be taken as low

values since there is a lot about the Mac that I just don't know yet. Also speed would be much slower on the older lowend Macs and much much faster on the expensive high end Macs.

Disk access is very fast. For a 102K byte text file, Q-emuLator took 3.2 seconds while my QXL took

4.3 seconds to load. To scroll the file from top to bottom took Q-emulator 1 min. 25 sec. while the QXL took 1 min. 20 sec. There is a QL demo program (you have probably seen it.) that shows the letters QL circling around a colored spire. The letters can't be seen when behind the spire. On the Q-emuLator, the letters circled 10 times in 28.3 seconds while on the QXL they took 27.8 seconds.

I Q-Liberated a small program that simply multiplied a number 1 million times. The Q-emulator took 5 min. 32 sec. while the QXL took only 30 seconds. No contest! I would guess the Q-emulator would do better with Minerva than with my JSU rom, but let's give credit to some very fast arithmetic algorithms in SMSQ/E.

EXTRAS

In addition to BBEdit Lite, Q-emuLator comes with some very useful QL information and freeware. There is a QL FAQ (Frequently Asked Questions) and Service (QL repairs) file. A Mandelbrot program, Mcopy (a fast microdrive copier) and Qsreen (picture editor) by Daniele are included as well as some games by M. Mano. Want to tinker or optimize the Q-emuLator or write a QL emulator for some other machine? Most of the C source code for Q-emuLator is also included!

LIMITATIONS

One limitation of Q-emuLator version 2 is that the mouse is not connected. However, the new version 2.1 is planned to hook up the Mac mouse to Q-emuLator. There is no place to hook in a QL net on a Mac. Flashing in Mode 8 is not supported nor is the TRA function.

The Mac prints through its serial port so that opening ser1 for printing works on Q-emuLator just like on the QL providing that you have a Mac compatible printer. However, I bought a special adaptor, POWERPRINT, that converts the Mac serial output to Parallel, and so far I can't get it to work with Q-emuLator. Thus, I must print to file and then use the Mac to print to the printer.

At the Boston QL show, Q-emuLator was demonstrated using a computer interface for an overhead projector. However, it was sluggish. Later the problem was found. When a second monitor (or in this case a projector) is attached to the Mac, Q-emuLator can not use the write directly to screen option. It must use the Mac screen driver which is much slower.

BEST POINTS

Once Q-emuLator is installed, it really does run just like a QL. Differences like using the key labelled OPTION for the ALT key (It's where the ALT key ought to be anyway) are very few. I was able to produce useful work right away.

Daniele has been very prompt answering questions or taking suggestions for improvements. His Email address is: sistest@ictp.trieste.it There are free Mac 68k and PowerMac demo versions of Q-emuLator that he can send via Email.

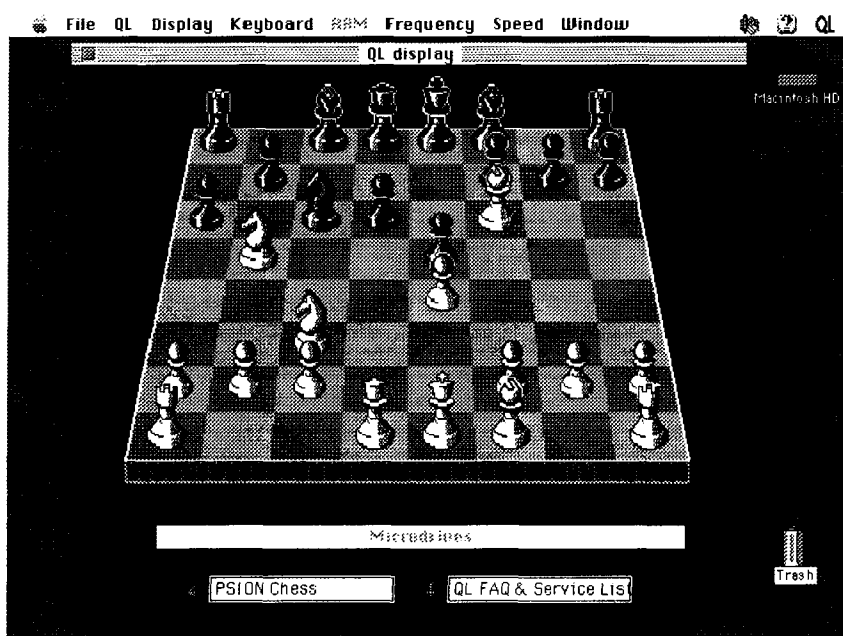

A strong point of Q-emuLator is its 16 page A4 manual. This covers everything in a concise, easy to understand manner. I am very impressed. Generally, programmers at the hacker level tend to be poor writers; they tend to

assume the reader knows all the arcane terms. I predict a notable career for Daniele who can program an emulator AND write so smoothly.

Q-emuLator version 1.1 (68000 version) is priced at 65,000 Lire (about \$40.00 or £25.00) Q-emuLator version 2.1 (Power PC version) is priced at 90,000 Lire (about \$60.00 or £38.00) Prices include postage and packing. Payment should be in Lire for orders from the USA and UK. Both versions can be obtained from:

Daniele Terdina
Via dei Navali 16/1
34143 Trieste
Italy

GRAPHICAL

Mini Graphics Printer	£15
Page Designer 3	£40
Scanned Clipart 1&2	£10
Vision Mixer 1	£10
Image Processor	£15
Convert-PCX	£10
The Clipart	£12
The Painter	£25
QRactal	£20
ST-O-QL	£12.50
3D Terrain	£12.50
Quick Mandelbrot 3	£15
Image-D	£10
Sidewinder Plus QL	£24.95
Open World	£18

TEXT

Banter	£15
Sidewriter	£15
DeskJet AS	£12
Quick Posters	£10
Text87 Plus4	£79
2488 printer drivers	£29
Typeset94 Deskjet driver for Plus4	£29
Fountext94+ Founted89 for Plus4	£39
Publisher Pack driver for Plus4£30 (Drivers for use with Lincdesign 2)	
Qindex	£20

UTILITIES

Screen Dazzler	£10
Dev Manager	£15
Screen Snatcher	£10
Super Disk Labeller	£10
The Cat	£5
QL-PC Fileserver II	£35
Files 2	£12
TaskMaster	£25
TaskMaster Hard disk	£35
Spellbound	£30
Spellbound S/E	£50
Cueshell	£40
QPAC1	£19.95
QPAC2	£39.95
QTYP2	£29.95
4Matter	£14.95
Locksmithe	£14.95
Floppy Disk Utilities	£18
Disk Mate 5	£37

GAMES/SIMULATION

5 Game Pack	£12.50
Grey Wolf	£12.50
Open Golf	£12.50
Return to Eden	£17.50
Quiz Master 2	£10

The Fugitive	£9.95
Fleet Tactical Command II	£39.95
FTCII Data Print Utility	£9.95
Flightdeck	£15
Spectrum Emulator ZM/128	£28
Spectrum Emulator ZM/HT	£40

PROGRAMMING

Basic Reporter	£10
QLiberator V3.36	£50
QLiberator budget version	£25
QLOAD & QREF	£15
Resident Program Manager	£10
EASYPTR 3 Part 1	£40
EASYPTR 3 Part 2	£20
EASYPTR 3 Part 3	£20
DISA 2	£40
DEA disassembler	£26
MasterBasic	£22
Q-Library Manager	£18

MISCELLANEOUS

Amd-Airplan	£10
Flashback	£25
Flashback S/E	£40
Music Manager	£12
Address book & Label printer£15	
Simple Mailmerge	£10

Software from Chris Boutal

GENEALOGIST 3	£45
GENEALOGIST 2	£25
GENEALOGIST BUDGET	£10

Software from Geoff Wicks

SOLVIT-PLUS 2	£15
QL-THESAURUS	£15
STYLE-CHECK	£15
QL WORDS PACKAGE	£25
(Solvit-Plus 2 + QL-Thesaurus)	
QL WRITER'S PACKAGE	£25
(QL-Thesaurus + Style-Check)	
ALL THREE PROGRAMS	£35

*Call, fax, email or write for a more
comprehensive 20 page catalogue.*

TERMS/CONDITIONS

Software is supplied on 3.5 DD disks. For software available on microdrive see catalogue. All prices shown are in UK pounds Sterling. Software is sent post free in the UK, overseas add £1.00 per order. Please make payments payable to 'Quo Vadis Design'. Payment in UK pounds Sterling currency only, Cheques (drawn on a UK branch of a bank or building society), Postal Orders, International Postal Orders and Eurocheques are all accepted. Goods remain the property of Quo Vadis Design until full payment has been received.

BUGS 'N FIXES

John Gregory, England, asks:

When I click on the help topic "net" in HyperHelp [or QD's Help] the QL freezes. All other topics I tried worked.

Jochen's reply:

If you look at the help_index file, you find that help on the topic "net" will be found in a file called "net". HyperHelp tries to open the file first, and if this fails, puts the help directory in front of the name and tries again. You probably guessed what happens. Opening a file called "net" will, of course, try to open a network channel. With long timeouts on the network, it looks as if the QL has crashed. Similar effects would happen if you open files called "ser", or "history" on SMSQ/E. The solution is easy, and I already did it here: rename the file "basic_help_net" to "basic_help_net_txt", change the entry in the help_index from "net net" to "net net_txt" and you will see that your problems disappear.

Some customers asked:

Some games do not work anymore when I want to start them under SMSQ/E.

Jochen's reply:

In the early days, when there was only the (slow) QL without GoldCard and SuperGoldCard etc., speed was all that counted. Most games programmers simply had to cheat and program round the operating system calls to gain the speed which was required to run the game. The main problem is that they had to access the screen directly (i.e. POKE onto the area between 131072 and 131072+32767. Using the screen driver would have been the correct way, but, the screen driver did not handle sprites etc. so it was impossible. When you start SMSQ/E on an ATARI with QVME, Extended4-Emulator or QXL and you switch to a higher resolution, SMSQ/E moves the base of the screen area to another place, as higher resolutions require more memory than the standard 512x256 pixels, which requires 32kBytes. Even when you switch the resolution back to 512x256, the display does not move back to its original position. The solution is to put a request and an IF clause into your BOOT program, and configure SMSQ/E to start in 512x256. If you don't want to remain in 512x256, use the DISP_SIZE command to change the display size in the BOOT.

Wolfgang Strate, Germany, asked:

In SMSQ/E, changing the TRA setting does not have any effect. What is wrong?

Jochen's reply:

Nothing is wrong. Any SER or PAR channel which is opened uses the current TRA setting as long as it is open, even if you change TRA. In QDOS, for example, you had to set TRA 0 before doing any graphics dump to a printer. Changing it back to TRA 1 to get the German Umlauts while the dump was still printing caused chaos, because buffered data was immediately translated - definitely an unwanted, if not disastrous effect. Now, in SMSQ/E, if you set TRA 0 (or open a channel using the "D" direct parameter) this channel will never use translation tables, whatever the setting might be at any time. This is the only way to handle buffered data properly. Being QDOS-compatible here would mean: you must not change TRA while anything is buffered, i.e. don't start printing anything else. There can be situations where you need to translate text, but also want to send untranslated printer control characters to the same channel. Of course, you do not want to open and close a channel so often, therefore we implemented the new procedure "UPUT". You can open a channel with translates, so that any Umlauts will be translated if you PRINT or PUT them into the SER or PAR channel. UPUTting characters to the same channel will send them untranslated.

Alf Kendall, UK asked:

If you use functions and procedures like the ones in QMENU which accept null parameters, and omit the last parameter, like PRINT FILE_SELECT\$(,flp1,,,,,0) then it works fine in SuperBASIC but QLiberator doesn't like it.

Jochen's reply:

In theory, QLiberator should accept it. However, there seems to be a bug in QLiberator which requires the last parameter to be given, e.g. PRINT FILE_SELECT\$(,flp1,,,,,0)

However, both examples above are equivalent to PRINT FILE_SELECT\$(,flp1)

so why would you give lots of null parameters without adding something at the end??? All it does is: it wastes memory and time! For EasyPTR, where you may need dummy parameters, you can fix this by adding a dummy last parameter \0 (for SuperBASIC).

Gérôme Grimbart, France, wrote:

QJUMP OR Jochen Merz Config Block

If like me your environment is mainly Pointer, then you probably know about the Config Block, or at least the Config program (whatever its name on your system).

For non-technical people, this is a very nice way to change the parameter of a program: Should the text be displayed black on white or white on black (or green on black, or red on white, ...)? Everyone has a personal choice (THE best, of course), and a good reason for it. The way the config block works allows programmers to make their choice, considering only what they like, and to leave the door open for other users (like me) if they do not like the way it is. Another example: where are the files for the program? The programmer may have a hard disk partition (as win5_), but the poor users may still only have a floppy. So do we have to patch the binaries, like in the good old days (remember converting MDV_ only programs to use FLP_...)? No, the Config Block is here for that purpose too.

The only limit to Config Block is the programmer's effort to use it. And the users' understanding of what the parameter means.

[... here is a definition of the CONFIG block, which was already listed in the previous issue, Editor]

... Every pointer is a WORD, so it must be within the 32K area of the config block.

This goes back to day one, and it was a good thing (except, maybe, for the length of the pointer...).

And then came the time for upgrading your software (Bug? who says there was a bug? It's a feature!). And the poor users has to reconfigure again his new software.

So Jochen Merz, a nice boy, thought: It would be wonderful if the new version could be learned from the old one.

It was day two, and it may have been a good thing.

On day three, Jochen Merz did the Config Level 2 specifications. And either he or I missed the point.

Jochen introduced a violent change in the config block: Before the Type of Item, he put a Long Word, the Item ID. And of course he changed the Configuration Level: now "02".

There are, according to his documentation, three kinds of ID:

- Global ID name, which could be used by many programs (like the colourway setting), must start with an underscore (underlined white space "_").
- Unique REGISTERED ID name (which are preferred).

- many unregistered local ID name (with possible conflicts), TOP byte must be 0.

And this could be acceptable, if there was no other way to do that.

But how can I get a Unique Registered ID name? Ask God! Or for the time being, you have to nicely ask Jochen Merz, who will give you a 3 letter prefix, so you can use the last byte for all your software.

It's not perfect, for two reasons: First, I do not like to have to ask (by mail, it will take a week for me, but for an Australian? Maybe a month! And you have to send a I.R.C. with your query). Second, It has the Internet Addressing Symptom! A long word has a lot of value. But the internet (in its beginning) divided the mathematical space of the long in classes (big, medium and small). What happens is now: If you have a need for ten computers, you needed a small class (wasting 245 addresses). If you have a need for three thousand, you needed a medium class (wasting a lot more...). And nowadays, available Internet Address is something difficult to find (read the press about this and IPv6!). Jochen's ID will have the same trouble. It looks fine, nice, but it won't resist to the time.

So what do you want to do? Stick to Level 1? Well, maybe... It has the advantage of having a PD config program, which doesn't need a license for software sellers. And the solution for avoiding having to redo the configuration exists in Level 1, without the need for the Long ID.

Let me explain. What's the use of the Item Selection Keystroke?

In the QJUMP config software, nothing.

In Jochen's MenuConfig (Level 1), nothing (it generates its own).

In Jochen's New MenuConfig (Level 2), nothing (same as before).

Ok, it's only a byte, but you have the best ID possible for a software: the Software Name field! Note: I do not say to make a Config Block for EACH parameter, but a config block will not usually have more than 256 parameters (thirty should be a maximum..., but you're at the keyboard...) So, my proposal is to use the Software Name as a first level ID, as when you upgrade a program, its name does not change (remember, the version is not in the name), and then use the Item Selection Keystroke to find identical items. In spite of modifying the structure, we can keep the Level 1, so it greatly simplifies the Config Program (You can still use the FREE QJUMP Config one). What you need to get the same level of service as with Level 2 is a small utility able to scan your old software and store the configuration in the database (as does the Level 2), or directly

modifying the new version (a check on the Type of Item may be very useful).

If you did not notice yet, I am against the specifications for Level 2. The only point in having them are the GLOBAL ID, especially for the colourways. But they limit them to the very restricted 4 (W/g,B/r,W/r,B/g) combinations. So that's not a good thing either (more and more software use Shaded/Striped texture!).

The only thing I still hesitate on Level 2, is the introduction of a new type "nothing". It's declared purpose is only to call the Pre/Post processing Routine. As I do not use them, I do not see the point, but why not? And now, I'm gonna translate all this!

Jochen's reply:

Dear Jérôme, the reason why MenuConfig ever saw the light of the day was: there had to be an easy way to update new versions of a program without having to change every setting manually.

We had two options: do something which is downward compatible with Config Level 1, or forget about the concept and have some "external" configuration files (like QTPI, QFAX etc. has with their _dat files). However, as programs don't know the "path" at least one configurable item has to be provided: the name of the _dat file. In general, I like the idea that a program carries its information, therefore I thought just extending the current config block would be the best approach.

Also, I did not want to rewrite all the structures and macros (have you ever looked at the config macros?) so just adding a longword ID was the easiest choice.

I can't really see your point of criticism at all, as MenuConfig works quite well, is easy to use and provides next to no compromise or overhead.

Let's go through the points you don't like: you don't like asking for an ID. ID's have to be unique, that's their nature! What other solution do you have to make sure that there is no clash (i.e. two or more people choosing the same ID) than having a big list, containing all assigned ID's? Of course, somebody has to maintain this list - could be me, Stuart, PROGS or whoever - but you have to ask. How else would you know that the ID you would like to use is not assigned yet?

Asking for an ID never posed a problem for anybody, and if it is urgent you can use a device called telephone [now, now children! - Dilwyn] - no IRC is required and it is fast, and, done in less than a minute, affordable to people even living in other continents.

I also can't see a problem in the fact a longword has been chosen. I do not want to go into detail, but everybody is welcomed to have one, more or

quite a lot of ID's. Do you think 256 config items are not enough? Fine, have 65536 per program. This would still leave space for between 65535 and 16 million other applications with 256 to 65536 ID's. Please don't tell me this is unreasonable - I don't think we will have as many applications in the lifetime of our operating system. And, in the very unlikely case, there's always room for expansion. There are no negative ID's assigned - so whenever we run out of space (maybe in the year 2300 or so) we use negative double-long ID's, giving 9223372036854775808 different ID's - that's hopefully enough!

Your suggestion of using the keystroke as an ID was something we thought of before introducing Config Level 2 the way it is now - we had a look at various CONFIG blocks and found that it would cause chaos on existing software. This meant a new CONFIG level had to be done anyway, and there was no way to define global ID's properly by using the keystrokes. It is quite possible that we need more global ID's soon.

Before level 2 was introduced, the definition has been put into the mailbox and it has been sent to the major software houses, so that it can be discussed and everybody seemed to be happy with it. Some ideas were brought in, which led to the new undefined item. You can do with it whatever you like, for example create complex menus (the QPAC2 sort-menu could not be handled with any of the existing items, for example).

My main question is: what is so bad about Config Level 2? It works, it makes life easy, people like it - and we already did the whole work. Every developer can benefit from it for free - we give the macros away for free. You don't have to use it, it is optional, as it can still handle Config Level 1. You are welcome to define your own config scheme if you want to, but - in which way would the user benefit now???

Afterthought from Dilwyn Jones - What hasn't been mentioned is how users without knowledge of assembler can use Config Level 2. With Level 1, there is a PD utility called BasConfig which helps you to create a config block by asking you simple questions and building it for you. Perhaps Jochen would consider doing an equivalent programming tool so that QLiberator users can make Level 2 Config blocks as easily as the old Level 1 block - how about it, Jochen?

Jochen's reply:

This is some work I was hoping that it would be done by the three users who wrote the various BASIC Config extensions. QL Today uses much more time than I thought, so I hope somebody else will be doing it.

Dilwyn Jones asks:

I have come across a somewhat annoying little problem when trying to unzip a ZIPPed file containing a BOOT program on a machine fitted with a Falkenberg hard disk interface. This system consists of a device called BOOT, used for startup of the hard disk. Unfortunately, this causes a name clash with a BOOT file being extracted from such a ZIP file. Does anyone know how to get around this problem?

Some versions of the Psion printer driver install utility seem to have a problem with installing a driver to work with a printer on a parallel port, e.g. on a Super Gold Card. V2.00 of Quill seems to have this problem. The solution (and I don't know why) is to install the port name as '2PAR' rather than 'PAR'.



MASTER SPY and SPY REVIEW

Roy Wood

Just a couple of quick comments about the reviews of SPY and Master SPY that appeared in the last issue of QL Today.

The problems that Norman Dunbar experienced with the screen not refreshing on his QXL are confined to the QXL itself. These problems were noted and a patch was put together by Dave Woodman (I believe). Richard Howe, the program's main author, was given this patch but managed to lose it in the period after ceasing to trade in QL programs. We are trying to locate the patch and get it built in to the re-released version.

The second thing that he mentioned was that you could not pass a file to the program to be edited on start up. That is, in fact, possible in the normal Toolkit II way and, for all of you menu_rext owners the following lines of SuperBasic can be built into a program to give you a pointer driven file selection to start Master Spy with a chosen file.

```
getfile4
EX DEV$ & 'MASTER';File$
DEFine PROCedure Getfile4
  file$=FILE_SELECT$('MASTERSPYSELECT'
  ,,WIN1,,,,,3,1)
RETURN
END DEFine
```

By the way it may be possible to get Richard Howe to do some other changes to MASTER SPY although a major re-write is pretty unlikely. I would

like to instigate a version that could use the full screen on a QXL, Atari or new Aurora. If there were enough people interested who are already users and would be willing to pay an upgrade fee I may be able to get something going. Do drop me a line if you are.



QFORMAT

PD Software Review

Dilwyn Jones

Norman Dunbar is an author of several well known and respected QL software such as Winback (hard disk backup utility) and the DJToolkit software. Perhaps less well known, but equally good quality, are his public domain software contributions to the QL scene. Here, I will look at a very useful and well written program for the rapid reformatting of used QL floppy disks.

QFORMAT is written in C68. The program is compact at only about 25kB long and does its job in a straightforward, no fuss way. It does the equivalent of reformatting a disk, but takes only a few seconds to do so. If, like me, you tend to accumulate several disks with various unwanted files on them, or you buy a batch of used QL disks at a show, for example, rather than go through the disks individually deleting all files on them, this program will save you a lot of time. Disks can also be renamed as they are formatted - the program allows you to write a new medium name as it re-writes the map area.

The program is simply executed with a standard EXEC command. there are no BASIC extensions to be loaded first. If your disk system does not support direct sector access, and that only applies to very old interfaces, you may not be able to use the program. The instruction manual for your interface will document the direct sector access if implemented. This includes all disk systems from Miracle Systems Ltd, for example. Usually you can spot direct sector access facilities from references to '*d2d' files or similar.

First, QFORMAT asks which floppy drive number is to be used. This can be a number from 1 to 8, though I have never heard of more than 4 disk drives being attached to a QL (the specification allows in theory for up to 8 drives). A minor disadvantage is that the program assumes that the drive name will always be 'FLP', but this will almost always be the case unless you have an old 'FDK' interface, or are in the habit of renaming your drives via FLP_USE or DEV commands. Actually,

if this was a serious problem, experienced users could load the program into a binary file editor and patch references to FLP to become FDK or whatever your system uses. Highly unlikely that anything this drastic would be necessary!

It can cope with DD, HD and ED floppy disks, but does not automatically distinguish the type, so you have to tell it whether to treat the disk as DD, HD or ED - it's quite simple, you know which type of disk you are putting at the drive by looking at the disk and simply entering the letters D,H or E as appropriate.

Next, you can either just press ENTER to give the disk a 'null' name, or type in a medium name of up to

10 characters, as you would use in a FORMAT command in SuperBASIC. You cannot add an extended specifier to this - for example, you cannot force the format to produce a single sided disk by using the '*' 11th character as you can in a FORMAT command. If you try, the program ignores the 11th character and formats the disk to double sided as before.

The formatting now takes place.

On my Super Gold Card system it takes a little over a second for a DS/DD disk. Before rewriting the map area of the disk, it checks for any bad sectors flagged during previous formats. The program cannot cope with bad sectors, so you are politely informed that the old

disk has bad sectors on it, and you should do a proper reformat using the FORMAT command, for example. It also checks that the disk really is formatted for the QL. If the disk is a PC disk (usually indicates that the user is a QXL user!), QFORMAT cannot cross-format it to become a QDOS disk in the same way as the QXLFormat program by Dave Walker would do, for example.

During reformatting, the program writes the 'random number' information into the disk map (like the FORMAT command does). This of course helps to prevent disk-swapping problems and helps the QL to detect when you have changed disks. If the program was used to generate 50 reformatted disks, and the QL could not differentiate between them, it would be about as inconvenient as the problems the computer has trying to detect changed DOS disks under SMSQ. If this were to happen, the computer may try to write some new information onto what it believed was the same

disk, damage it, then come up with a bad or changed medium error when it was too late, perhaps! Full marks to the author for thinking of this and making the program write a random number during formatting rather than just simply producing 'clone' disks.

After the disk has been reformatted, you have the choice of reformatting the same type of disk, or going back to change the disk type. This is very useful, so before starting to reformat the disks, make sure that you have separated all the DD disks into one pile, HD disks into another, and ED disks into another if you have mixed types. Then you can do all of one type first, then move on to the second type and so on, until all have been done.

The instructions are brief and to the point, just a short text file (a Quill _doc file), adequately explaining how to use the program. In truth, I don't think you'll need instructions, the program is so simple to use.

The program is meant to do a single specific task, and does it competently. Perhaps its only slight shortcomings are that it doesn't detect the

disk type automatically (which may take longer while QDOS tries to determine the type with sector access calls than by asking the user to specify type with a

single letter entry), and it isn't pointer driven, though for such a short and simple program it doesn't bother me too much that it is keyboard-only. If the program is updated in the future, I would like to see a facility to cross-format DOS disks (which you can buy pre-formatted) into QDOS disks, thus saving on the monotony of formatting brand new disks!

I have used this program for a long time and find that it's one of those programs which make me think how I ever managed without it!



```
QFormat 1.04
by Norman Dunbar.

This program will QUICKLY re-format a number of floppy discs.
However, each disc MUST have been properly formatted before AND
there must be no bad blocks on the disc. This will be checked.

You must specify the correct disc type :-
DD = 1440 sectors, HD = 2880 sectors or ED = 6400 sectors

Which drive is to be used (1 - 8) ? 1
```

```
QFormat 1.04
by Norman Dunbar.

Place a 'DS/DD 720 Kb' disc in 'flp1.' then press ENTER or alternatively,
type in a medium name (10 chars max) QLToday_1
```

S.J.P.D. SOFTWare.

WWW Page <http://www.di-ren.co.uk/sjpd/homepage>
CompuServe ID = 101325,2750
Internet Email stephen.johnson@almac.co.uk

36, Eldwick Street,
Burnley,
Lancashire,
England.
BB10 3DZ.



Tel / Fax +44 (0)1282 701767.

QL HACKERS JOURNAL. (2)
XCHANGE Version 3.90L. (2)
GHOSTSCRIPT 2.6.1. (6)
QL INFOZIP Release 005.
PRETTY GOOD PRIVACY. (2)
C68 Release 4.21a. (8)
PERSISTENCE OF VISION V2.2a. (6)
M. EDWARDS Demo Disk.
G. WICKS Demo Disk.
QL WAR Version 3.02.
Z80 Cross Module Assembler.
POINTER MICROEMACS. (3)
LINEDESIGN Fonts. (8)
MONOP. (Monopoly)
TREK. (Star Trek)
LIB LIST. Version 1.1.
SMALL "C" Compiler.
C.L.I.P.S. (2)
Q.T.P.I. Release 1.60.
MARK KNIGHT Utilities Disk.
"GOING ONLINE" Text Files.
SBASIC PE KIT.
D-I-Y TOOLKIT. (3)
ProWesS Documentation. (2)
QFAX version 2.80
George Gwilt Assembler & Disassembler.

THIS IS A SMALL SAMPLE OF THE
180 + PACKAGES ON OFFER.

The number in brackets = the number of disks in the package.
No number = 1 disk package.

*Plus 68 disks of the best
assorted in QL Public Domain,
Shareware & Freeware!*

*A full range of emulators for
use on either IBM
compatibles or the Amiga.*

*Over 200 disks of classic
literature & assorted text files.
Including the complete works
of Shakespeare.*

Gold Card &
Super Gold Card Users!

**Temporarily
Sold Out.**

Extra high density disks

Now In Stock

Only £2.50 Each Or £22.00 For 10.

Inclusive of UK postage.

QL pre-copied disks are £1.25. each, fully inclusive of media and return UK postage.

Please add 50p per disk for none UK orders.

For a catalogue disk which details over 500 disks of PD, Shareware, Freeware! & Text Files offered.

Send a QL formatted disk and return postage.

Payment by Cheque & EuroCheques drawn on a UK bank, made payable to S.J.P.D. SOFTWARE.

English banknote also accepted. No facilities for credit cards.

17/10/96.

"From The Nurse Helping To Keep The QL Alive."

600

Noughts & Crosses

Ron Humphries, U.K.

This is not your ordinary Noughts and Crosses! You're only allowed three noughts or three crosses at any one time. As you make your fourth move, your first disappears, so to win you have to anticipate which of your opponent's squares is conveniently going to be vacated.

This listing is my first attempt (only came across this game a couple of weeks ago) and so the presentation is a touch simplistic (no fancy pointers) with the minimum of error trapping; e.g. you can't play to an occupied square and you have to enter properly the number of the square in which you want to play.

At present the game is for two players or you v. you. I've not yet worked out a strategy for myself let alone the computer.

So see if you can. It might, with analysis, turn out to be as trivial as its ancestor, i.e. always a draw or a forced win for one player or another - I'd very much like to know.

A few programming points (which you don't need to read). There are eight winning lines and as the order in which the moves are made is significant in this version, there could clearly be 48 different combinations.

So to establish a win I do a simple numerical sort of a player's last three moves and then, using SuperBASIC coercion, see if the result is "INSTR" with eight winning ones. These are held in "win\$", separated by zeroes.

The moves are stored in a six-element array so that with different offsets, only one set of procedures is required.

That's it really. Fast enough not to need compiling (well, on an SGC QL) so simply "lrun flp1_ox3". Have fun.

```
1000 REMark Start of 3-only noughts and
crosses test
1010 REMark 01/08/96
1020 win$="3210654098707410852096309510753"
1030 FOR j=1,2: WINDOW #j,512,202,0,0: PAPER
#j,0: INK #j,6: CLS #j
1040 CSIZE #0,0,0: INK #0,6: CLS #0
1050 INK 4: PRINT: PRINT: PRINT
1060 CSIZE 1,0: PRINT " Unlike simple
noughts & crosses, which with proper play"
1070 PRINT " always results in a draw, the
outcome in this version is"
1080 PRINT " not so obvious."\
1090 PRINT " The reason being that ";
1100 INK 6: PRINT "ONLY THREE X's or O's ARE
ALLOWED ON"\ THE BOARD.";
1110 INK 4: PRINT " As you play your
fourth, your first ";
1120 INK 6: PRINT "disappears!"\
```

```
1130 INK 4: PRINT " Have fun - press any key
to start.."
1140 INK 6
1150 PAUSE: CLS
1160 draw_board: init
1170 PRINT #0, "X starts - any key to
begin..": PAUSE
1180 REPEAT play
1190 :
1200 REPEAT make_x_move
1210 find_move "X"
1220 check_move
1230 IF NOT wrong: EXIT make_x_move
1240 END REPEAT make_x_move
1250 update "X"
1260 :
1270 REPEAT make_o_move
1280 find_move "O"
1290 check_move
1300 IF NOT wrong: EXIT make_o_move
1310 END REPEAT make_o_move
1320 update "O"
1330 :
1340 END REPEAT play
1350 :
1370 DEFINE PROCEDURE update(n$)
1380 board%(place,1)=1
1390 IF n$="X"
1400 offset=0: INK 2
1410 ELSE : offset=3: INK 4
1420 END IF
1430 print_it
1440 IF ox%(1+offset)
1450 spot=ox%(1+offset): board%(spot,1)=0
1460 wipe_it
1470 END IF
1480 ox%(1+offset)=ox%(2+offset):
ox%(2+offset)=ox%(3+offset):
ox%(3+offset)=place
1490 IF ox%(1+offset)
1500 check_win
1510 END IF
1520 END DEFINE update
1540 :
1550 DEFINE PROCEDURE find_move(n$)
1560 REPEAT get_move
1570 CLS #0: PRINT #0, "Which square for
";n$;" ?"
1580 ox_go$=INKEY$(#0,-1)
1590 IF ox_go$ INSTR "123456789"
1600 EXIT get_move
1610 ELSE : clot_message
1620 END IF
1630 END REPEAT get_move
1640 place=ox_go$
1650 END DEFINE find_move
1670 :
1680 DEFINE PROCEDURE draw_board
1690 CLS
1700 REMark drawing vertical board lines
1710 FOR v=50,58,66,74: LINE v,40 TO v,64
1720 REMark drawing horizontal board lines
1730 FOR h=40,48,56,64: LINE 50,h TO 74,h
1740 END DEFINE draw_board
1760 :
1770 DEFINE PROCEDURE clear_board
1780 CSIZE 3,0
1790 FOR j=1 TO 9: CURSOR
board%(j,2),board%(j,3): PRINT " "
1800 CSIZE 0,0
1810 FOR j=1 TO 9: CURSOR
```

```

board%(j,2)+100,board%(j,3): PRINT j
1820 END DEFine clear_board
1840 :
1850 DEFine PROCedure clot_message
1860 CLS #0: PRINT #0, "Don't mess about!"
1870 PRINT #0, "Pick an empty square numbered
1 to 9 only."
1880 PRINT #0, "Press any key to continue..":
PAUSE
1890 END DEFine clot_message
1910 :
1920 DEFine PROCedure check_move
1930 wrong=board%(place,1)
1940 IF wrong: clot_message
1950 END DEFine check_move
1970 :
1980 DEFine PROCedure print_it
1990 CSIZE 3,0
2000 CURSOR board%(place,2),board%(place,3):
PRINT n$: INK 6
2010 CSIZE 0,0
2020 END DEFine print_it
2040 :
2050 DEFine PROCedure wipe_it
2060 CSIZE 3,0
2070 CURSOR board%(spot,2),board%(spot,3):
PRINT " "
2080 CSIZE 0,0
2090 END DEFine wipe_it
2110 :
2120 DEFine PROCedure check_win
2130 FOR j=1 TO 3: win%(j)=ox%(j+offset)
2140 FOR k=1 TO 2
2150 FOR j=1 TO 2
2160 IF win%(j+1)>win%(j)
2170 swap=win%(j): win%(j)=win%(j+1):
win%(j+1)=swap
2180 END IF
2190 END FOR j
2200 END FOR k
2210 line%=win%(1)&win%(2)&win%(3)
2220 IF line% INSTR win$: win
2230 END DEFine check_win
2250 :
2260 DEFine PROCedure win
2270 CLS #0: CSIZE #0,3,0: PRINT #0, "A WIN
FOR ";n$
2280 CSIZE #0,0,0: PRINT #0, "Do you want
another game? (y/n)"
2290 REPEAT reply
2300 reply%=INKEY$(#0,-1)
2310 IF reply% INSTR "yn": EXIT reply
2320 END REPEAT reply
2330 CLS #0
2340 IF reply%="y": init: ELSE : CLS: EXIT
play
2350 END DEFine win
2370 :
2380 DEFine PROCedure init
2390 DIM board%(9,3),ox%(6),win%(3)
2400 RESTORE
2410 FOR j=1 TO 9
2420 board%(j,1)=0: READ board%(j,2): READ
board%(j,3)
2430 END FOR j
2440 clear_board
2450 END DEFine init
2470 :
2480 DATA 140,76,162,76,184,76
2490 DATA 140,93,162,93,184,93
2500 DATA 140,109,162,109,184,109

```

And here's another challenge from the Editors of QL Today:

Based on the listing and rules of Ron's special Noughts & Crosses we would like to ask you to program the computer's turns. Depending on the number of programs returned, we would like to organise a public computer tournament at one of the next QL shows to see who programmed the best algorithm. The program should not use any special extensions, it has to be able to run under plain SuperBASIC. The program should be ready end of December.

Amiga "QDOS"

Simon N Goodwin

CROSS EMULATION

I've been testing lots of software on the 68060 recently, using a beta version of Amiga Qdos 3.24, and had good results with Carlo Delhez's emulators. My test machine was an Amiga A4000 with 30 Mb RAM and CPU accelerators from GVP and Phase Five.

Spectator 1.52 ran at around 250 per cent of real Spectrum speed, on the NewBench and ZXSpeed tests. It still reports 97 per cent - I guess it's doing something to make reports come out at 100 per cent or thereabouts, whatever the real speed.

I pushed the CPU MODE 8 update rate to 50 Hertz with ACE_PRIORITY 16,1 and got almost exactly true Spectrum 48K speed.

Paging in 128 mode still imposes a heavy burden. With ACE (the Amiga CPU screen redraw routine, similar to the one on the QXL) running at 25 Hertz I got just 70 per cent of real Spectrum 128 speed on ZX BASIC tests, rising to 94 per cent when I switched to four colours and blitter screen decoding. Still not bad, but this is a 50 Mhz 68060 with very fast RAM...

Results for Xtricator, with CLCKFREQ, were more impressive. At the default settings I got a 16.2 MMHz Z80 engine and 2025% performance. Switching to the blitter I pushed that up to 20.7 MHz, 2588 per cent (72 frames) with XTR_IO reduced to a priority of 1.

In fact the RAM speed is not a major factor as most of the time Xtricator seems to run from the (8+8K) 68060 cache. I'd be interested to know the timings for a QXL. I guess these also depend on the screen mode and update rate.

I also got the 'lite' Mac Qdos emulator running happily - albeit slowly - on the Amiga, under the Shapeshifter Mac emulator! It was slow, but usable

- I think the speed overhead came from the 68K emulator written in C, as Shapeshifter is normally pretty speedy as it runs most Mac stuff at full speed. It's no competition for Amiga Qdos, but nice that it works at all.

QXL SPEED

Looking through the clock change information and timings in the second issue of QL Today, it seems that the QXL spends about a third of its time updating the display, converting it from Qdos format to suit the PC display card. Extrapolating from Terry Harman's figures, it appears that a 7 MHz QXL would have no time at all for anything else! This should re-assure some of the doubters who wonder how a 25 MHz QXL can be so much faster than the current 20 MHz model...

QDOS PD CD

There's loads of good material in the Qdos Public Domain, yet it's a slow and tedious process collecting it, on floppy disks or by modem. Wouldn't it be great if someone put together a compilation of Qdos PD on CD-ROM? Even though few QL systems have CD ROM drives, users could access the files on other micros and transfer them to their QL as required, either using Msdos floppies (readable on QLs) or, more neatly, the 'handlers' available for Amiga, Unix, PC etc, to write the files directly to Qdos floppies.

I have arranged to have tens of megabytes of Public Domain Qdos material, including emulators, compilers, tools and games, compiled onto the next Amiga Format cover CD, to tie in with an article I've written about Qdos.

Providing AF get the CD mastering right (!), there should be literally thousands of Qdos files on the CD. I've sent a complete C68 update, including full documentation and sources, from Dave Walker, the latest InfoZip and various other packers, George Gwilt's new 020/030/040/060 assembler and disassembler, the entire DIY Toolkit (with 32 bit and Minerva two-screen patches on all the tasks) and far more utilities and games than I have time to list.

QL program source and text files are readily readable from the Amiga desktop or shell, but you'll need to transfer tasks to Qdos disks to run them (emulating or otherwise). The CD includes Frank Swift's QLFileSystem, which can read and write Qdos DD and HD floppies on an Amiga, and a similar program for PCs, QLT27DOS.

I've produced an Amiga version of Mark Swift's DOC2RTF utility, which converts Quill DOCs into Rich Text Format, readable by modern word-

processors on Mac, Amiga and PC. The new version works with PC Quill files as well as Qdos ones, and translates important Msdos and Qdos diacriticals into ANSI codes. It has point-and-click file requesters with sensible defaults, so there's no need for typing. The original SuperBASIC version is among the Amiga Qdos support files, on the disk in source and Turbo-compiled form. The new version is written in Hisoft BASIC 2; source is included as well as the stand-alone task.

The Compact Disk is in ISO-9660 format with long file names. I know Linux can read this (so can NetBSD, and all Amigas of course) but this may clobber PCs expecting '8.3' file names. I considered asking AF to use the clumsy translation table format to please QXL owners, but decided that compiling the CD would be tricky enough, without that extra burden. I know very little about how far PCs have got to go before they support long file names. I don't know if ST users with CD-ROM drives can read long names.

I'm told that the long names will not be a problem for people with Windows 95 or NT, although I'm not likely to try it myself. Others could use a PD PC program called CDR.EXE to read the files. This is in various (Amiga) PD libraries including the Fred Fish collection, and also on one of the the current (October 1996) Amiga User International cover floppies. It works as a replacement shell that supports long file names and wild-cards. It needs MSDOS 3.2 and MSCDEX v2 as well as a PC with a CD ROM driver, and includes C source.

I've tested the files on QL, Gold Card, Thor XVI and Amigas with 68000, 68030, 68040 and 68060 processors, and applied some patches for compatibility with caches and 32 bit memory addressing. Bear in mind that these are all freely distributable files collected from authors, the Net and PD libraries, and they will not have been tested on all Qdos configurations, so 'your mileage may vary' - but I've tried to go for stuff that is relatively compatible.

The CD will arrive on the UK news-stands at the end of September. Amiga Format comes from Future Publishing of Bath, UK, in floppy disk and CD-mounted versions. The CD one costs a pound extra, but that seems a small price to pay for all those QL files!

With any luck this will also drum up some interest in Qdos from technically minded or curious Amiga owners.



QUBBESoft P/D

Proveyors of QL Hardware & Software



Public Domain & Shareware Software

Over 80 Disk's of Public Domain & Shareware Software including Peion Xchange V3.90L, C68 'C' Compiler V4.20, QL Emulator (AMIGA) V3.23, Molecular Graphics V5.12, LineDesign 2 Demo, MicroEmacs V3.11, Page Designer 3 Demo, Climes, QFax, Ghost Script V2.61, QTPI, Hackers Handbook, etc.,

£1.00p per Disk + Postage & Packing

Stamped addressed A5 Envelope or International Reply Coupon for current Catalogue



LineDesign EZ Clip-Art Collection 1

Over 100mb of Clip-Art files on a SyQuest EZDrive Cartridge. All files will load directly into LineDesign 2. Various themes are catered for such as Food, Backgrounds, Cartoons, Music, etc Also Includes over 200 PFF Fonts and Thumbnail Cat for ease of selection.



£25.00p inc Cart & Cat

Inc P&P (UK) +5% (Euro) +10% (ROW)



LineDesign HD Clip-Art Collection 1

As above but on 50 High Density Floppy Diskettes, excludes some Clip-Art due to availability of space.

£25.00p inc Disks & Thumbnail Cat

Inclusive of P&P (UK) +5% (Europe) +10% (ROW)

PD EZ Collection

Over 100mb of QL PD & Shareware Software on a SyQuest EZDrive 135 Cart. Includes all the Software in the current QUBBESoft P/D Catalogue as follows:-

Disks PD 1 to PD 14, Disks SPECIAL 1 to SPECIAL 60, C68 V4.20a 8 Disk set, Ghostscript V2.61 6 Disk set, MicroEmacs V3.11, GNU Utils, XLisp V2.1d, Star Trek Reference, Adv '93, COWO Screens, DIY Toolkit, Qitaly Disks 14 to 29, LD2 Clip-Art Food 1 to Cartoons 4.

£25.00p inc Cartridge

Inclusive of P&P (UK) +5% (Europe) +10% (ROW)

PD HD Collection

As above but on 50 High Density Floppy Diskettes, excludes Qitaly Disks 14 to 29 and some LD2 Clip-Art Disks.

£25.00p inc Diskettes

Inclusive of P&P (UK) +5% (Europe) +10% (ROW)

**Floppy Disks
3.5in DS/DD
Pre-Formatted QL
(1440/1440)**

£3.00p

For 10

+50p P&P (UK only)

EZ Literature

Over 100mb of Popular Books in ASCII text file format on a SyQuest EZDrive 135 Cart. Inc Viewer and files as follows:- Sherlock Holmes, Religious & Bible, Edgar Rice Burroughs, Jules Verne, Shakespeare, H.G. Wells, Mark Twain, Robert Louis Stevenson, Classic Horror, Lewis Carroll, Hans Christian Andersen, Brothers Grimm, Jane Austen, Thomas Hardy, Lucy Maud Montgomery, Bronte Sisters and lots lots more.

£25.00p inc Cartridge

Inclusive of P&P (UK) +5% (Europe) +10% (ROW)

**Floppy Disks
3.5in DS/HD
Pre-Formatted QL
(2880/2880)**

£2.50p

For 10

+50p P&P (UK only)

QUBIDE AT/IDE Interface

Allows you to connect modern AT/IDE Hard Drives, including the EZDrive 135, to your QL. A massive amount of storage space can now be made available for your programs and files. Compatible with Super Gold Card, Gold Card, Trump Card and most memory expansion systems for the QL, also Minerva and SMSQ/E.

Now only £55.00p

Inclusive of P&P (UK) +5% (Euro) +10% (ROW)

QPLANE Powered Back Plane

QPlane is a powered back plane for the QL, primarily designed to be used with a PC Mini Tower Case and a PC PSU. QPlane has two power connectors, known as P8 & P9, which marry up with the special power connectors of the PC PSU to supply all the power requirements for your QL and expansion units. QPlane has 3 expansion slots.

£25.00p

Inclusive of P&P (UK) +5% (Europe) +10% (ROW)

Products in Pipeline

The Aurora: The QL's Graphics Card, is a replacement for the QL's Motherboard. Introduces new Graphics allowing higher resolutions varying from 512x256 upto 1024x768 depending on type of monitor connected. Can be connected to VGA, SVGA and Multisynch Monitors as well as the normal QL Monitor. Qimi compatible mouse interface also included.

The Super Duper Gold Card: This will be the successor to the Super Gold Card. Uses Motorola Cold Fire processor which is equivalent to 68040. Different memory configurations upto 64mb using industry standard 72 pin SIMM. Bi-directional Parallel Port. On board switch mode power supply unit which will detect input voltage and adjust output voltage accordingly.

38, Brunwin Road, Rayne, Braintree,
Essex. CM7 5BU. UK.

Tel: +44 (0)1376 347652 Fax: +44 (0)1376 331267
Email: QUBBESoft@aol.com

Comment: Future imperfect?

Jonathan Hudson

Jonathan Hudson is the author of a number of communications programs for SMS/QDOS computers. Such "notoriety" ensures that you become a focus for all sorts of questions and comments. This article discusses some topical issues related to SMS/QDOS and the Internet that have been presented recently.

As the mainstream computer press becomes increasingly infatuated with the Internet, it is hardly surprising that SMS/QDOS community should express aspirations to run Internet applications directly from their machines. I've been presented with the following scenarios:

- "ftp and telnet are portable Unix programs, c68 is a compatible compiler. ftp and telnet can easily be ported to SMS/QDOS."
- "Aurora will make a World Wide Web (WWW) browser possible."
- "Aurora will make producing a Java interpreter very easy."

No one wishes to be the harbinger of bad news (would I let that stop me?), but these comments, somewhat paraphrased to protect the innocent, are, at best naive. The problem of native (TCP/IP) Internet access from SMS/QDOS systems is not primarily a hardware problem, it is a software problem of quite large proportions, and perhaps more importantly, illustrates just how short the SMS/QDOS community is of talented programmers willing to undertake this type of major project.

There is no hardware reason why at least the first two above could not have been successfully produced at any time in the last four years given sufficient effort and dedicated programmers.

First, let's look at how TCP/IP implementations are produced on other systems. There are a few well known examples we can examine:

Unix (Linux/NET3). This TCP/IP code is freely available (and usable) under the GNU Copyleft. The TCP/IP layer, as in many Unix implementations, is completely integrated with the kernel (the inner most layer of the operating system). Extracting this code to build a QDOS system is non-trivial, it would require some detailed knowledge of the way a Unix kernel works, a high level of 'C' proficiency, as well as experience of QDOS internals.



Shared Library implementations. The Amiga (AmiTCP) and Windows (Winsock) "retrofit" TCP/IP capability by implementing them as shared libraries rather than in the operating system. The Amiga code is freely available, again using this utilising this code base would require in depth knowledge of the Amiga operating system.

Good knowledge of the theory and practice of TCP/IP networking is also mandatory!

One thing that the above all have in common is ancestry, the original BSD (University of Berkeley, California) net-

working code. This type of implementation is often known as a 'sockets' implementation because of its programming interface. The reason why the Amiga and Windows variants are implemented as shared libraries rather than embedded in the operating system is one of preference, however the enormity of the task should not be overlooked; we are looking at nothing less than a network operating system.

Once this base NOS layer exists then porting TCP/IP applications such as ftp or telnet does become quite easy and more complex applications (a Web Browser for example), are possible, in however many colours your hardware supports.

Without this basic layer, then it is all a pipe dream. As an example of program portability, I have many examples of networked client-server systems that are equally at home (as either client or server) on such diverse operating systems such as Unix, Windows NT, AmigaOS and VAX/VMS with just a re-compilation necessary.

The role of the shared library is best illustrated by a picture. In the figure below, the "sockets layer" manages all the TCP/IP services through, in this example, a modem CSLIP connection.

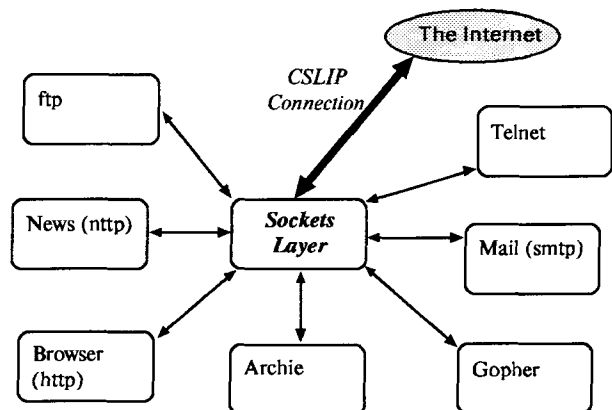

Note that all the possibly concurrent tasks (ftp, telnet, mail *et al*) may be to different host computers somewhere in the grey "Internet" box; they are however all managed by the "sockets

layer". Obviously, the messages coming back from these hosts / programs in the "Internet" are completely asynchronous, the "sockets layer" must be able to handle all these data packets and direct them to the correct application (via their 'sockets') on the SMS/QDOS system. Perhaps this is not so easy after all.

For what it's worth, my opinion is that the Linux NET3 code would be the best basis for a SMS/QDOS application, using a shared library approach via the proposed c68 RLL system.

In all the above examples, there is no need to produce device drivers *per se*, transports such as (C)SLIP and PPP are layers within the library built on top of the standard low level serial devices. If this device layer is defined correctly, then it would not preclude using a bidirectional parallel port or Ethernet device for higher speeds via additional dynamically loaded modules.

I must admit to having spent some time this summer browsing through the NET3 sources to evaluate how much work would be involved -- it is rather a lot, perhaps six man-months work to produce the base sockets layer and some simple text based applications such as ftp and telnet.

The resource requirements would be quite high too, based on the sizing of the AmiTCP implementation, I anticipate that the shared library

would require at least 200 kB, before any applications are run. A practical, graphic Web browser would probably require resources of the order of 68030/25Mhz, 8Mb RAM and hard disk, even then it would be rather slow.

There are some technical difficulties (hardware and software) to undertaking some of the projects alluded to here.

- CPU. All CPUs available for SMS/QDOS platforms are somewhat under-powered by modern standards. Programs like Java and Web browsers have expanded to fill the raw power offered by the latest Intel and PowerPC offerings. There is nothing proposed for QDOS vaguely near production that offers the necessary horsepower (the new QXL2 may come close, but the I/O may be less than optimum). Viewing a complex HTML file on a 25Mhz/68030 system is tedious; on a Pentium 100 it's instantaneous.
- Memory. Again, many modern technologies (e.g. WWW/Java) are based on the premise that the system will have somewhere between 8 and 16Mb RAM.
- Disk availability. The low prevalence of hard disk units in the QDOS community does not encourage the production of systems that require large amounts of storage.
- Development Tools. Dave and Keith Walker

WE SUPPORT SINCLAIR

QBOX USA

COMPUTER BULLETIN BOARD SERVICE
(810)254-9878

**We support *all* SINCLAIR COMPUTERS
(QL, SPECTRUM, ZX81, Z88, Thor, QXL)**

- Now in our 3rd year on-line round the clock since October, 1993
- Full message area and File Download areas
- We carry all popular SINCLAIR message areas from Europe
- Calls from 14.4k--300 baud are welcome
- QBOX - USA runs on a SINCLAIR QL with Super Gold Card, Hermes, QUBIDE, 200MB drive, USR sportster 14.4 modem

→ NO FEES CALL US

have worked unceasingly to give us the excellent c68; but this is two talented enthusiasts in their spare time. We do not have a symbolic debugger. There is still no RLL system. This is not a criticism, it's just an observation of how short of human resources we are; I'm extremely grateful for what we have.

I expect any JAVA system that could be ported to the QL would be a C++ implementation and thus a non-starter.

- **Hardware Robustness.** When a QDOS application crashes, it may take out other programs, or the whole machine or just insidiously corrupt some system memory structure that causes *random* problems at some later time. Linux, Windows 95/NT, Amiga, OS/2 *et al* all offer various degrees of virtual machine protection against this.

As our 'C' applications become more complex, then this becomes significant. As an example, an obscure bug in a beta c68 that passed all Dave's regression tests under QDOS showed up instantly when run as a cross-compiler on a Linux system. The Linux debugger also pinpointed the source of the problem instantly.

- **Operating System.** The QDOS operating system offers very little support to programmers (compared to Unix, Windows 95/NT, Amiga, OS/2 etc) in writing complex programs. Things that are easy on the above platforms may require unpleasant amounts of assembler programming involving often poorly (or non-) documented system structures. This is again an issue of the trade-off of simple to use, low hardware requirements v. complexity and robustness.

Wouldn't it be useful if the QPTR and SMS/QDOS manuals were available on the Internet and BBS? It would save a few trees; such low volume paper publishing can hardly be profitable. Then there would be much less excuse for programs that don't work under the latest operating system versions. I despair when I read reviews of 'commercial' programs that don't even take advantage of the Pointer Environment.

- **Open standards.** With such a small developer base we cannot afford proprietary standards. A WWW browser that only supported 'Line-Design' format graphics is not very useful when the graphics in millions of Web pages are in well documented industry standards such as GIF, TIFF and JPEG.
- **User interest.** I wonder just how committed the SMS/QDOS user base is to having complex, modern programs running on their computers. Two messages were posted on the BBS network inquiring how many people would be interested in:

- Collaborating on an TCP/IP project.
- Using the results of such a project.

The results (essentially zero and four) do not encourage the considerable effort required.

This view is reinforced by the comments of a trader that most users "only want a *better printer driver* for QUILL" than just about any other software.

Visit a QUANTA sub-group meeting; do you see a majority of users using the Pointer Environment and hard disks? I don't.

Many users prefer this simplicity and the easy programming environment that SMS/QDOS *BASIC provides; I'm not sure that this simplicity, compactness and the ability to run on low end systems is compatible with the demands of modern, graphical, Internet-worked applications.

A trader promoting ProWess (the new PROGS graphical environment) recently commented "*parts of ProWess package are so horribly complicated to install or configure that they have gone away from the basic simplicity of the QL system*". This is symptomatic of the whole problem: ProWess makes it easier to write graphically complex programs, the price is that it can be difficult for the user to install or configure (but perhaps easier to use?). The resource requirements also shoot up. The parallels with complex graphic environments on other platforms are all too obvious.

The views expressed in this article were prompted by some discussions with (inter-alia) Roy Wood (Q-Branch) and Dilwyn Jones. The original question was "Will Aurora facilitate access to the Internet (and a Web browser or Java interpreter)?" The answer, of course, is no; only a huge software effort can do that -- Aurora will just make the display somewhat prettier. It cannot be a magic panacea for the massive effort involved in porting a complex software system. Of course, if Aurora 256 colour drivers are produced, then this may act as an incentive to developers.

The opinions herein are solely those of the author; I don't expect they are shared by the majority of readers. If you disagree, why not write to the editor to tell everyone why I'm wrong, or post for the defence in the INTL.QL BBS echo? I look forward to reading your comments -- particularly if you're currently writing a freely distributable sockets library for SMS/QDOS computers. ■

Editor's note: *This Article is the property of Jonathan Hudson, but at his express wish it may be freely quoted or copied. Usual QL Today copyright restrictions do not apply to this article.*

SUPER GOLD CARD LIMITED OFFER

£75 Allowed on your Gold Card
while stocks last.

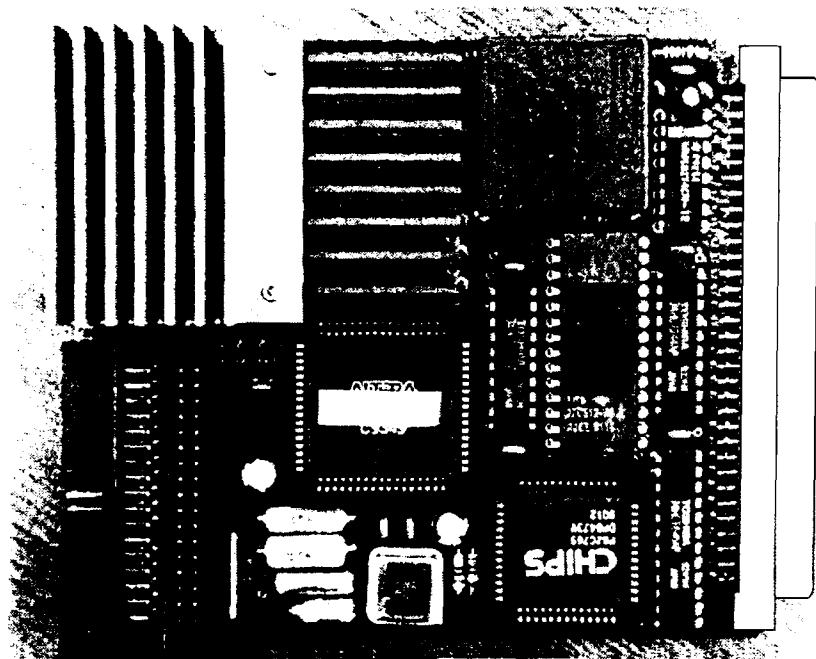

- * *3 Times Faster*
- * *68020 processor*
- * *4M bytes of RAM*
- * *2 Disk drive ports*
- * *CENTRONICS port*
With FREE printer cable
- * *£275.00 + £5 postage*

*To Order please send a cheque
drawn on a U.K. Bank for
£280.00 (or £205 + a Gold Card)
payable 'QUANTA' to:*

*J Taylor
145, Barrowby Rd.
Grantham
Lincs.
NG31 8AJ*

*(for more information
phone 01476 563404)*

Letter-Box

March R. Renick, Jr. - USA - wrote:

1. IQLR AND QL WORLD

I am sure I am not the only one that considers the demise of IQLR a great loss. I wish to express my approval of your conciliatory comments concerning Bob Dyl, and at the same time make a few observations and/or comments concerning Bob and IQLR.

It has been my experience over my life span of 71 years that people are prone to jump up and down and scream to the world that they have been wronged and at the same time blame everyone else for their loss except themselves.

Before, I get further along in this letter let me make a major observation with reference to IQLR vs QL World. Those individuals that published QL world were in the business of making money over any other cause. They never suffered any loss except revenue when they stopped publishing. To my knowledge, they never intended to refund any sum of money for the uncompleted subscriptions owed to their subscribers. If the subscribers pursued or attempted to receive a refund, it ultimately cost more in time and temper plus unanswered letters than it was worth. In my opinion they made out like sin, as the saying goes.

We (all of us that subscribed to IQLR) have only to look on our shelf at the five volumes representing 5 years of sweat, labor and love for getting IQLR out on time and besides that, the contributors that Bob Dyl kept after to write articles, etc. can be justly proud of their contribution in whatever way they could.

Those individuals, such as yourself, who have devoted your life to producing hardware, software and articles concerning computers and especially our QL's should be even more aware and also proud of your contribution to making information, etc. about QL's easier for those not so well versed.

I can understand individuals feeling like they have been put upon, but surely they can find a place in their heart to see the great loss we all have suffered in almost losing Bob to life itself. He was a taskmaster of unequalled determination. He was a dynamic individual that I had the pleasure of meeting in person at the Oak Ridge, Tennessee, USA get-together last year in June.

I had talked with him by telephone many times over the past 5 years, and there was never a time that he was too busy to help me understand a problem and how to solve it, if he knew the answer. If he didn't know the answer, he would say so and either contact someone else for me or give me that

persons name, address and telephone number in order to help me with my problem. He never once suggested payment for his time and effort spent. The time will come when we'll realize just how much everyone of us owe him for all of his love, time and effort put into the IQLR cause.

For my part, I would never ask for a refund of any kind. One has to personally experience having had one or more heart attacks and been fortunate enough to live to tell about it. I've had my share of injuries over the years, even including quadruple by-pass surgery. I am very thankful for having lived after going through these experiences.

I guess what I'm really saying is: Leave the man alone, he has suffered enough for anyone's lifetime. He wasn't expecting to receive a fortune in publishing IQLR. We owe him a debt of gratitude, for sure.

The task that you three gentlemen have taken on is exemplified by your producing, so far, two good issues of QL TODAY. Of course, there will be articles, understood and helpful to many individuals and some that are too complex to comprehend, but you do have a good selection, especially in the time frame you've had to put it all together.

2. A QL USER'S EXPERIENCE

My field of endeavor for 42 years was in electronics. I became interested in Sinclair computers when I attended a computer show in Washington, D.C. back in the early 1980's. Investing in computers at that time was too expensive for me, however I was intrigued by the ZX-80 series that Clive Sinclair started out with. I guess you might say that I was hooked, for sure. Of course in time I moved on to the ZX-81, then the American Spectrum, the Timex TS - 2068 and then finally the QL. I have yet to become knowledgeable as a programmer. It seems that I am a user more so than one who can write programs.

I retired from the federal government in January 1988 and my wife and I moved to the state of Florida after living and working in the Washington, D.C. area for 42 years. My only regret is that there are to my knowledge no one interested in the Sinclair QL here in central Florida. I spend a lot of time writing and talking to those that are still active in the Capitol Area Timex/Sinclair User Group of which I am still a subscriber even though I cannot attend the meetings anymore. Of course the group only has a token number of faithful attending members and they are still devoted and interested in the QL. Back in the mid 80's the groups membership was in the 50's or more, but time has a way of weeding out member after member until it's lucky to survive for another year, but it does.

I remember the prediction over ten years ago that the QL would be dead and buried in less than a year, but it's being used with new programs and new hardware keep coming on line.

I have three QL's that are operational and for sure I use two systems on a daily basis. I was worried when I contemplated retirement that I wouldn't have enough things to keep my interest and enthusiasm going, but I find that I really do not have enough time to learn and work with numerous programs that are available and not too complex that would prevent me from using them. I subscribe to several magazines that are still publishing or starting up such as: QUANTA, QL TODAY, CATS, NESQLUG and UPDATE. I have as near complete as possible the QUANTA library disks, which contain a wealth of information and programs, etc. There are also many pieces of software that I have purchased. At my age, I know that I'll never fathom the depths of all of them, but I'm still learning and enjoying the programs that are both useful and interesting to me and they help keep my mind active as well.

My #1 system consists of the QL with JSU Rom, Super Gold Card, dual DD, HD, ED 3.5" drives plus dual DD 5.25" drives, My monitor is the original Sinclair Vision Monitor. I have added the Di-Ren keyboard interface, with 101 key keyboard, the Qimi internal interface for a mouse, also I have replaced the 8049 with Hermes.

My #2 system is basically the same as above with the following exceptions: I have a Gold Card, single DD,HD,ED drive, along with a single DD drive and dual DD 5.25" drives. No mouse interface.

Both systems have STAR printers, models NX - 1001 and NP - 10 they are 9 - pin , no color.

My #3 system is not as extensive, but usable with the original QL membrane keyboard, dual DD drives, 3.5" and dual DD drives, 5.25", Trump Card with disk drive interface, along with four drive interface. The monitor is a Maganavox RGB 40, no printer.

Snippet's Corner I

M. Knight.

Introduction

This series of articles has two aims: one is to provide a library of routines for SuperBASIC programmers to incorporate into their own programs: the other is to show how well laid out code looks and to encourage good programming habits. In general the code I provide will not be optimised

primarily for speed as I aim to make routines readable above all else. Speed is considered and is especially important in certain of the routines but readability is always given first place.

The articles are aimed not at beginners nor at the experienced and knowledgeable but at middle level programmers who might want to improve and add to their SuperBASIC libraries. Still I hope even the experts will find some of it useful and to set you thinking I will throw in the odd question or problem for the more ambitious. You don't need to solve such problems to use the code.

Most of the routines already written are to help with presentation of data on the screen or with conversion from one form to another. This is no accident; I have often seen programs where the functional engine is superb but the presentation and user interface is a disaster. Converting data to readable forms is often the first step in making a program easy to use. Some of the routines have little in common other than this theme of converting data or presenting it.

If there are other areas of programming you want covered write to the editor of QL Today and ask. I can't guarantee to please everybody but if there is a flood of requests for one particular sort of routine I will consider writing some custom code. Remember my programming time is limited so anything that requires masses of time to write and debug will not be considered. If you don't have a clue whether something is trivial or immensely difficult then write and ask for it and we'll let you know.

General programming tips

Before getting stuck into this issue's code I will suggest some general guidelines for SuperBASIC programming that might help you to write more readable code. Writing readable code is essential if you want to make debugging as easy as possible, since you may not see a listing for months or even years if it is working well. If after all this time a user finds a bug or suggests a new enhancement then a clear, well ordered listing will jog your memory better than some of the messy programs I have seen. With this in mind a few suggested rules are in order.

Some people will tell you that rules are made to be broken but this is rubbish; some rules are made to be broken, but this one never: always use proper indenting when writing SuperBASIC. In addition, always use variable, PROCedure and FuNction names that are meaningful and relate as closely to their function as possible. It is a matter of opinion, but I also think using all upper case variable and routine names in SuperBASIC is bad practice too.

This is because it can make it harder to pick out calls to routines written in SuperBASIC among built in keywords.

The most important rule is never, ever, ever use GO TO or GO SUB in any program except as a temporary patch while debugging. GO TO and GO SUB are redundant in SuperBASIC and make programs much harder to read and debug. If you are one of those who moans "but I can't get by without them!" then keep reading QL Today and hopefully I and others will show you how. Don't worry, it is still possible to write bad programs without using GO TO or GO SUB if you want to.

Common features

The following is a list of the common features in the routines.

1. All variable names begin with "Tk_" to separate the Snippet's corner toolkit names from your own. Leave this part out if you wish but if you do make sure you are consistent about it.

2. Keywords are generally UPPER CASE, so variable names are Mixed Case and routine names are first part Mixed Case, last part UPPER CASE. This means in a listing keywords, variables, PROCedures and FuNctions may be clearly distinguished.

3. Routines will generally work on any QL with any ROM (AH, JM, JS MG, Minerva), with Turbo or Q-Liberator and in SBASIC. Some of my routines work better with Digital Precision's Turbo than with anything else because they were developed for such use. If there are restrictions it will be for a good reason and I will give the reason.

4. Routines use a common set of line numbers starting at 30000 to allow you to MERGE them together easily and to fit them into your own programs. Each article will also contain demonstration code which can be discarded once you have run it and understood it. The demo lines will start at 100.

5. Explanation is limited to how to call the routines and a few lines about any limitations, with examples. Experiment!

The Wrapper's delight

The first thing to do is type in listing 1 and then

Listing 1.

```
100 MODE 4
110 WINDOW 504,102,4,23
120 WINDOW#2;304,100,4,125
130 WINDOW#0;504,32,4,224
140 FOR Chan=0 TO 2
150   PAPER#Chan;0
160   INK#Chan;7
```

run it. It demonstrates the word-wrap routine that has been in use for years in dozens of programs and is one of the most useful I have ever written. Over 90% of my programs contain this PROCedure! It will word-wrap any text that will fit in any window in any CSIZE. Adventure writers are especially happy to see it working. Some of the code may look odd at first glance but this routine works with all QL ROM versions and even works around some bugs in them.

Try to work out why line 30050 exists.

The other main routine is a FuNction that RETurns a string representing hours, minutes and seconds between the two numbers given, as long as the later one is higher. The numbers should represent times in seconds taken from the QL clock or calculated by some SuperBASIC. Both parameters should be positive and within the LONG INTEGER range, so it works with up to over two billion seconds (2,147,483,647 seconds to be precise). Numbers outside this range may appear to work but the results are unreliable and in any case this gives 596,523 hours, 14 minutes 7 seconds which ought to be enough! To display the number of hours minutes and seconds in 4000 seconds type:

```
print elapsed_time$(0,4000)
```

...and for fun try:

```
print elapsed_time$(0,2147483647)
```

The following appears to work but the result is wrong:

```
print elapsed_time$(-2,2147483647)
```

...can you work out or find out why? (Hint: think about the way QL numbers are stored).

The third routine, Leading_ZERO\$, is called by Elapsed_TIME\$ and several other routines in the series as well as having uses of its own. It simply ensures a minimum length for a string with the leading end padded with the character of your choice, e.g. try:

```
for n=1 to 10:print leading_zero$(rnd(1 to 100),3,"0")
```

...or:

```
for n=1 to 10:print leading_zero$(rnd(1 to 100),3," ")
```

It is handy for right justifying screen text or tables of integers and is used by Elapsed_TIME\$ to pad out each number in the string to the correct minimum length of two characters.

```

170 BORDER#Chan;1,2
180 CLS#Chan
190 END FOR Chan
200 :
210 TestText$="The word-wrap works in any size or shape of window as long as the text will fit.
It is very fast and adaptable and works with AH, JM, JS and MG ROMs, Minerva or SBASIC and SMSQ
or SMSQ/E. It also compiles well with Q-Liberator or Turbo."
220 FOR Chan=1 TO 2
230 Word_WRAP Chan,TestText$
240 END FOR Chan
250 CSIZE#2;2,0
260 Word_WRAP 2,"It works in any CSIZE too!"
270 CSIZE#2;0,0
280 :
290 TimerTime=DATE
300 REPEAT TimerLoop
310 AT 6,0
320 PRINT "Press the ESCape key to stop timing.";
330 AT 4,0
340 CurrentTime=DATE
350 PRINT Elapsed_TIME$(TimerTime,CurrentTime);
360 IF INKEY$(#0)=CHR$(27) THEN EXIT TimerLoop
370 END REPEAT TimerLoop
380 :
30000 DEFine PROCedure Word_WRAP(Tk_Channel%,Tk_Any$)
30005 LOCAL Tk_FirstChr%,Tk_SpaceFound%,Tk_WrapLoop
30010 IF LEN(Tk_Any$)=0 THEN RETURN
30015 Tk_FirstChr%=1
30020 REPEAT Tk_WrapLoop
30025 IF Tk_FirstChr%,LEN(Tk_Any$) THEN RETURN
30030 Tk_SpaceFound%=" " INSTR (Tk_Any$(Tk_FirstChr% TO ))
30035 IF Tk_SpaceFound%>0 THEN
30040 IF Tk_SpaceFound%=1 THEN
30045 Tk_FirstChr%=Tk_FirstChr%+Tk_SpaceFound%
30050 PRINT#Tk_Channel%;!"";
30055 ELSE
30060 PRINT#Tk_Channel%;!Tk_Any$(Tk_FirstChr% TO Tk_FirstChr%+Tk_SpaceFound%-2);
30065 Tk_FirstChr%=Tk_FirstChr%+Tk_SpaceFound%
30070 END IF
30075 ELSE
30080 PRINT#Tk_Channel%;!Tk_Any$(Tk_FirstChr% TO );
30085 RETURN
30090 END IF
30095 END REPEAT Tk_WrapLoop
30100 END DEFine Word_WRAP
30105 :
30110 DEFine FuNction Elapsed_TIME$(Tk_StartTime,Tk_CurrentTime)
30115 LOCAL Tk_Hours,Tk_Minutes,Tk_Seconds
30120 IF Tk_CurrentTime<Tk_StartTime THEN RETURN "Hr:Mn:Sc"
30125 Tk_Seconds=Tk_CurrentTime-Tk_StartTime
30130 Tk_Hours=INT(Tk_Seconds/3600)
30135 Tk_Seconds=Tk_Seconds-(Tk_Hours*3600)
30140 Tk_Minutes=INT(Tk_Seconds/60)
30145 Tk_Seconds=Tk_Seconds-(Tk_Minutes*60)
30150 RETURN Leading_ZERO$(Tk_Hours,2,"0")&": "&Leading_ZERO$(Tk_Minutes,2,"0")&":
"&Leading_ZERO$(Tk_Seconds,2,"0")
30155 END DEFine Elapsed_TIME$
30160 :
30165 DEFine FuNction Leading_ZERO$(Tk_AnyNum$,Tk_Figures%,Tk_Lead$)
30170 IF LEN(Tk_AnyNum$)<Tk_Figures% THEN
30175 RETURN FILL$(Tk_Lead$,Tk_Figures%-LEN(Tk_AnyNum$))&Tk_AnyNum$
30180 ELSE
30185 RETURN Tk_AnyNum$
30190 END IF
30195 END DEFine Leading_ZERO$

```

Easy Export from Z88 Pipedream into QL Quill

*Beryl and John Crawley, Welwyn Garden City,
England*

After several years' recording data for historical research on a Psion Organiser II, we tired of the small keyboard, and took advantage of Bill Richardson's Z88 offer. The QWERTY keyboard and silent operation make it ideal for use in search rooms and libraries, but there were two disadvantages.

Firstly, data can be transferred from the Psion Organiser to a Quill document via RS232 using FILES, IMPORT _Ser2hz [*interesting, didn't know you could import from a serial port directly into Quill, learned something new today! - Editor*] but the QL just hangs up when the same procedure is followed with the Z88. The IMPEXP program from the Quanta Library transfers data in two steps:

First, a _lis file is created on disk or microdrive, then this file is imported into the Quill document. When data is sent from the Psion Organiser via RS232, the end of file character is CONTROL Z - but this seems to be missing from the Z88.

Our solution to this problem has been to use the translate facility in the Z88 printer driver, to turn the \ character into the end of file CONTROL Z (i.e. change character 92 to 26). A \ is then used at the end of each Pipedream document, to terminate the transfer. We never use the \ in our texts: anyone needing to use the \ could choose another little used character, such as @ (64), ~ (126) or | (124) to translate into 26.

Data transfer from Z88 to QL is now as simple as the accustomed transfer from the Psion Organiser - and quicker than the two-step method of IMPEXP. You can also import the Pipedream document into an existing Quill document, by loading the document, then moving the cursor to where the Pipedream document is to be inserted.

To use our method, load Quill on the QL, check that the Pipedream document loaded on the Z88 ends with \ (or whichever other character you have changed to 26), witch off the Z88 and connect it by serial cable to the Ser2 slot on the QL. Switch on the Z88 again and press the PRINT command (diamond PO) but do not enter it. One the QL, command FILES IMPORT _Ser2hz BY LINE and enter: then immediately, without pausing, press ENTER on the Z88. The "importing" message will appear on the QL screen - if not, try again.

The second problem was in using the ' (British Pound), which terminated a transfer if the Z88 printer driver was not modified to get rid of control characters (as recommended in the README file). Once the control characters have been removed, the £ sign on the Z88 (163) can be translated to 96 - the £ sign on the QL.

With these two changes, the right hand side of the Z88 printer editor would read:

Translations	A	B	C
Character	163		
Changes to	96		
Character	92		
Changes to	26		

Even easier? If you can avoid using the £ sign anywhere in the Pipedream text to be transferred from the Z88 to the QL, then there is no need to change the Z88 printer editor: just remember to END the Pipedream document with a £ sign.

■

"Just Words" Reply

Geoff Wicks

I do not usually reply to reviews, but Gary Norton's problems in multitasking my programs have given me cause for concern, especially as QL-THE SAURUS is intended to multitask with word processors. I would be grateful if you would allow me the space to discuss this and other problems that users of my software range have reported.

MULTITASKING: Until now I have had no reports of multitasking problems. This is probably because most customers appear to be QPAC2 and Pointer Environment users. Multitasking works perfectly in this environment.

Gary Norton refers to two multitasking problems. Firstly, the programs crash frequently when used with Xchange and Perfection SE and, secondly, it is cumbersome to have to refresh the screen using F4.

I have been unable to reproduce the first problem on my systems. If there are other users who are having this problem, I would be grateful if they could let me know, giving details of their hardware and software set ups. I would also be interested to hear the experiences of any user who runs the programs under Taskmaster.

I can agree with Gary Norton over his second problem, but this applies to most QL software when it is not run under an environment that preserves screens. There is an undocumented feature of SOLVIT-PLUS 2 and QL-THE SAURUS v. 3.00 that can help in this situation.

You can leave these programs at any point where a cursor is displayed. When you return to the program, if F4 fails to refresh the screen, try pressing ENTER or "n". These will usually return you to the main menu screen.

HARD DISK: Some users have reported difficulties in running the programs from hard disk or subdirectories. This problem is almost certainly caused by an active DATA_USE command directing the program to look at the wrong drive or directory. Reset DATA_USE to the correct drive and directory. It is only needed when loading, and can be restored to the old value after loading is completed.

All the programs carry out a number of checks to determine the default drive and directory. These can be passed by DATA_USE, OPTION_COMMAND\$ or parameters by EX commands. The first check is DATA_USE. If a DATA_USE command is found the other checks are not carried out. If enough users complain that this is a problem, I will modify the code.

ATARI TT: All the programs, with the exception of QL-THESAURUS v. 3.00, will not run on ATARI TT systems as the programs are Turbo compiled. On the STYLE-CHECK disk is a QLib version of the program, which will run on an ATARI TT. A QLib version of SOLVIT-PLUS 2 is available on request.

QLiberator is more compatible than Turbo with the new operating systems, and it is good to hear that this compiler may shortly be updated. If there is a significant speed increase, I will give serious consideration to compiling my complete program range with QLiberator.

WRONG MODE: If you accidentally enter the wrong mode in SOLVIT-PLUS 2 or QL-THESAURUS v. 3.00, just press ENTER. This will return you to the main menu.

SMSQ: There is a small bug in STYLE-CHECK when run under SMSQ. If the delay is set to -1, this appears on the configuration screen as "-". At runtime this is no problem, but if you try to save it as a default it is also saved as "-". On reloading the program crashes. The bad news is that there is no solution to this bug, which appears to be an incompatibility problem between a Turbo compiled program and SMSQ.

The good news is that if the value of -1 is saved correctly the bug is harmless. You can do this in 3 different ways:

1: Return to QDOS for the one time you wish to save a default of -1. 2: Correct the Style_def file with a text editor. 3: Use the QLib version to save the default.

STYLE-CHECK DATA BASE: The STYLE-CHECK data base can be edited by the user. One user wrote that he would like a facility to retain some commands in the data base, but to make them "non-active". This is possible. When STYLE-CHECK searches its data base it looks for Chr\$(10);word;:". If you change the colon for another character, say #, you will make the comment non-active.

FOREIGN LANGUAGES: I am often asked if my programs can be used for languages other than English.

SOLVIT-PLUS 2 is designed as a universal program and is supplied with English, Danish, French, German, Italian, Norwegian, Spanish, Swedish and Welsh word lists. ASCII word lists in other languages can be loaded into the program, although these lists may require slight modifications.

QL-THESAURUS has a data base that is separate from the main program, and this can be edited by the user. In theory it would be possible to write a data base for a foreign language, but this would be a major task. It took me 2 months to write the data base and 1 month to revise it. Should a foreign language user write a data base for his language of commercial standard, I would be happy to help him in converting the entire program to his language.

Gary Norton will be pleased to hear there is now a USA English data base.

STYLE-CHECK may or may not be adaptable for a foreign language. Until some one tries it, I cannot be certain. Many of the statistical routines will be usable in other languages, but the program must be calibrated to make the statistics meaningful. This is done by running a large number of text files, from children's stories to graduate theses, as test material through the program. It should also be possible to write a data base for a foreign language. I would, of course, give my help by any serious attempt to do this.

INTEGRATED WORD PROCESSOR: Many users say they would like the thesaurus and style-checker integrated into their word processor. This observation should be made to the authors of the word processors. Should anyone be writing the new super all purpose word processor for the QL, they can expect my cooperation.

■

Black Knight Review

Mark Knight

Introduction

Black Knight is a brave effort as it is the first chess program since the original and innovative Psion Chess from the early days of the QL. At the time Psion Chess was original both because of the possibility of a 3D display and because it played much better than most other microcomputer chess programs. To try to replace it with an up to date program is a bold move and Black Knight does just that.

The first advantage of Black Knight is that it works on modern QL or SMSQ systems with floppy disks, hard disks and expanded memory. Psion Chess will fail on most QL emulators and doesn't easily run under SMSQ or SMSQ/E. Users of Psion Chess had to find ways to patch that program or lose the use of it when they upgraded their systems, while Black Knight runs on anything even vaguely QL compatible with 640k RAM or more and at least a floppy disk drive.

First impressions

Black Knight has a simple but non-standard interface and I found it very easy to start playing within minutes of backing up the disk. The program beat me very quickly in the first game but then I am not very good at chess and most chess programs beat me. I played a number of games over the first few days and quickly got used to Black Knight, finding it easy and hardly requiring the manual. Some of the icons used were initially confusing but once looked up in the manual nothing was hard to master. Moving pieces is very simple, just click on them with the mouse and the pointer becomes the piece, then move it to the destination and click again to put it down. Even without a mouse it is fine as the pointer system works well using the cursor keys. I don't have a mouse on my system but had no trouble though I did appreciate the increase in usability on a borrowed QL.

Playing games

Within a few days I was back in practise and I could consistently beat level two and often beat level three. This just shows I am not much good at

chess any more as I used to consistently beat Psion chess on level six and it plays better than Black Knight. Using a loaned QL I played Psion Chess against Black Knight four times (both running on 16Mhz Gold Card systems) and Psion chess won every game. The programs were given roughly equivalent time to think rather than playing on levels with the same number, so this was a fair match.

You may feel this limits the usefulness of Black Knight as an opponent but I think it makes little difference unless you can beat the upper levels consistently. The ideal chess opponent is said to be one that wins twice as often as you do, and Black Knight on level three was able to do that for me. With a few weeks determined practise I would expect to regain some of my old skill and beat level seven or eight fairly often but there are ten levels so I would still have a worthwhile opponent. You will need to judge for yourself whether or not this is likely to be the case for you.

I had some highly entertaining games with Black Knight and found that the best option was pretty much the same as with any chess program: play openings that lead to tight and complex positions. One bad mistake though and the program leaps on you, crushing your pieces and checkmating you in very short order. In common with most chess programs Black Knight tends to shuffle its rooks around aimlessly in tight locked up positions, allowing you to gather your pieces for an attack.

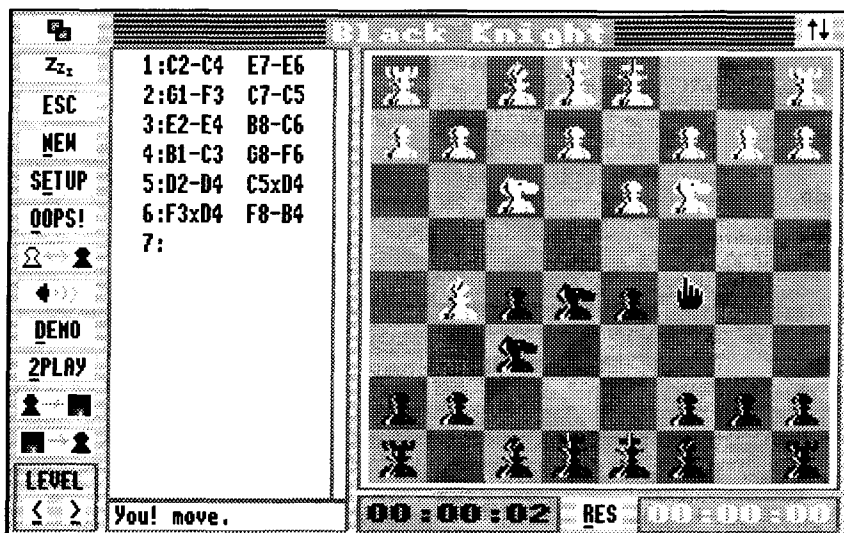

Once again, make a wrong move during your attack and Black Knight pounces with great eagerness.

Again in common with other chess programs, once you have the program in a position where you can shortly checkmate it throws pieces away in order to delay the mate by a move or two. This adds to the fun. I found a bug after checkmating Black Knight as I took back a few moves with the

Miracle Systems

QXL2

Fast Hardware Emulator for the PC

68EC040 processor

£295 inclusive

25MHz clock

or GOLD CARD + £195

8M RAM

or SUPER GOLD CARD + £100

QL Net

RECYCLED GOLD CARD

Accelerator card for QL

68000 processor

16MHz clock

£100 inclusive

2M RAM

Battery backed RTC

Please quote credit card number and expiry date
or make cheque payable to "Miracle Systems Ltd"

MIRACLE SYSTEMS LTD
20 MOW BARTON
YATE
BS17 5NF
U K

Tel/Fax: +44 (0)1454 883602

"Oops" option and tried to checkmate in a different way. Black Knight had become terminally confused and would not allow me to move my queen, flagging every move as an illegal move. It also made illegal moves and I had to save the position, quit the program and reload in order to recover.

This bug was easily reproduced but it seems to matter little as it only occurs once you have won a game anyway. The author will be tackling it and future versions should be free of this problem. The confusion also occurs sometimes before a mate has been found if "Oops" is used but I could not find out the precise circumstances in which this was true. I never ran into problems unless moves had been taken back during the course of a game and most of the time I didn't use this facility anyway. Recovery was always easy, just save the position, quit Black Knight and reload.

The manual

The manual is tiny, just six sides of clearly printed A5 and it is not badly written. It is too sparse for my liking as I feel every Pointer Environment (PE) program manual should be written with the first time user in mind; after all the purchaser may be buying Black Knight as their first pointer driven program. A little more information on installing into subdirectories would be helpful too, with a single stage by stage example to help those new to subdirectories. As the program is so simple to use little extra would be needed and it would help some users a great deal.

Irritations

One of the things that irritated me about Black Knight was the non-standard user interface. PE programs usually conform to a common layout and use much the same keyboard shortcuts such as F2 for the files menu etc. Black Knight ignores all that and uses its own set of icons laid out in a non-standard fashion. If this provided faster access or some other advantage over the usual way of doing things it would be worth it, but it doesn't. I think the author should take a look at LineDesign and QD and a few other Pointer Programs and rewrite the appropriate parts of Black Knight so it conforms.

The standard Config program is not provided though Black Knight must be configured using this program if it is to be installed on a hard disk or any device other than flp1_ [sorry, did not notice this - it NOW is included - Jochen]. I have the Config program as I have several pointer driven programs but once again the purchaser buying Black Knight as their first such program might have a hard time.

I believe Config is a royalty free program so it could be put on the disk without another thought.

Conclusion

Black Knight is a flawed but excellent program. For most users it plays chess well enough to keep them entertained for years and is easy to use. If the non-standard interface is brought into line with other PE programs it will be even easier and could not then be faulted on ease of use. It is expensive by QL game standards but offset against this is the massive amount of effort involved in writing and debugging a chess program. If you are a chess lover it is certainly worth serious consideration.

■

ATARI QL-Emulator

Jochen Merz

I don't want to go too deep into history, here just a short overview: the first QL-Emulator was a board from Norway, made for Mega ST and 520/1040 machines. Based on a ZX8301 it provided ordinary QL resolutions. Two years later, the Extended4-Emulators was born in Germany. It could handle Mode 4 only, but in standard and "extended" 768x280 pixel resolution (this is the maximum you can get non-interlaced from 50Hz Monitors and TVs). Both emulators were based on QDOS with some add-on drivers.

Then QVME appeared - a "proper" VME-Bus card which can be plugged into Mega STEs and TTs. Resolution, frequencies etc. can be adjusted in software, therefore it was the most flexible QL display adaptor. Then SMSQ/E for the ATARI appeared which would also allow you to run on ATARIs with all three emulators as well as on the 640x400 71Hz ATARI monitors - without any emulator.

SMSQ/E for the ATARI is still the QL emulation which uses most facilities of the machines (which are, unfortunately, not built anymore): ATARIs high-end machine was (some years ago) the TT - two of them still do a very good job here and for many customers. Based on a 32MHz 68030 it will handle any size of RAM up to 266MB without loss of speed (FastRAM concept). It also supports all the available ports properly - 4 serial ports (some with high baud-rates and high throughput) - I have two modems connected to one machine which can be active at the same time, print via PAR and update software via SERNET and the machine does not get noticeable slower. All kinds of harddisks and removable media (up to 8 drives)

are well supported, and it is even possible to access DOS or TOS (ATARI) partitions from SMSQ/E - very useful!

The TT is the only machine which supports memory protection via Memory Management Unit. Most useful, accesses to invalid addresses which "wrap" in all the other systems can be trapped. Lots of bugs in various software remained undiscovered until SMSQ/E ran on the TT - thanks to the TT a lot of buggy software has been fixed.

As said before, ATARIs are not built anymore, but they are still available second-hand, very reliable and also still the best-supported SMSQ/E machines. I wouldn't want to swap my TTs against PCs.

QPC

SMSQ/E takes over the PC

James Hunkins, USA

It is such a wonderful day for writing a review. The sun is out, the air is fresh, and I am sitting on my porch enjoying it all while I write this on my trusty laptop computer.

Wait a minute, you say. A laptop. This means that this article was written on a PC or Macintosh? Could Jim actually be using the 'other' computer?

The answer is yes and no. This is being written on a PC compatible laptop. But it is being written with the Text87Plus4 word processor under SMSQ/E. This is made possible with the amazing new program called QPC.

QPC is a QL emulator. An emulator runs code from one computer on a totally different computer. This is accomplished by translating the code as it runs to the native (the new computer's) processor's equivalent code. In addition, the emulator has to map the original system's hardware calls to match the native system's hardware.

We have seen QL emulators previously for computers such as the Macintosh and the Atari. Both these computers use 68000 family processors, just as the original QL and its expansion cards do. This greatly simplifies the emulator (but by no means trivializes it).

However, PC computers use the Intel family of x86 processors which have a totally different architecture consisting of different instructions, internal registers, etc. In other words, most 68000 (QL type) instructions will not exactly match x86 instructions. This makes it much more complicated to do an emulator and requires much more processing horsepower.

QPC pulls it off. By some clever coding by Marcel Kilgus (QPC) plus the efficient SMSQ/E (by Tony Tebby), QPC will turn any PC with a 486 processor or better into a QL running SMSQ/E. This means that you can now have a portable QL or that you can turn your PC at the office or home into another QL, even if you can not afford the QXL (a comparison with the QXL hardware emulator card comes later).

This article discusses QPC in some depth. It includes performance issues, features (new and restrictions), and system comparisons. A few notes on what I ran into when using QPC are also included.

As Shipped from the Factory - QPC and SMSQ/E v2.76

QPC is shipped on a single floppy disk with 13 pages of instructions/information. Instead of running QDOS, it comes with the faster, compatible SMSQ/E v2.76. SMSQ/E is a replacement for QDOS and is under constant development by Tony Tebby, the original author of QDOS. If you are not familiar with SMSQ/E, you should refer to the many articles on this operating system found in previous issues of Quanta, IQLR, and QL Today.

The documentation is adequate for QPC installation and usage.

To run QPC you need a PC compatible machine with a 486 or faster processor. You can not use a 386 or lower machine as QPC uses some of the extra 486 instructions.

The video card should support VGA and/or Super VGA [SVGA] (800x600 resolution, 16 color). If your video card's Super VGA mode does not support 16 colors (some of the newer ones only support 256 or more colors), you will not be able to use the 800x600 graphics mode.

Since SMSQ/E includes the pointer environment, a mouse or similar pointing device is recommended (but not required). This device can be either serial port or PS/2 based.

QPC also provides support for floppy (QDOS and PC formats) and hard drives and Audio CD drives.

QPC runs under DOS (up to version 7.0). It will not run under Windows (3.1, 95, NT), OS/2, Unix or any operating system or memory device driver that uses protected memory (see installation notes). Instructions are included that may make it possible to run it on machines with Windows '95, but it seems that this doesn't always work. Perhaps you will be lucky. But the rebooting back to DOS method will always work.

Usage Notes

Installation: Installation is very simple. You place the floppy disk into the drive and type 'INSTALL'.

A very pleasant picture is loaded onto the screen with QPC spread across it. When you see this you might be tempted to believe that you could produce this type of image with QPC. Sorry, but it was probably done with PC software, as QPC and SMSQ/E do not support enough colors yet to achieve it (but you never know about the future, since your PC based graphics can support them).

The install program then leads you through a short installation in which it copies the needed files to either a floppy or your hard drive (recommended). It also modifies some files during the installation, so it is necessary to NOT write protect your QPC disk. If you don't follow the simple instructions in the manual and have instead set your QPC diskette to write protection, you will discover some of the careful thought that went into this program. When I did this (yes, I should have read the manual first!), a simple note popped up on the screen telling me to remove the write protection from the disk. After I did this and pressed a key, the installation continued without a hitch. Most PC based programs would have aborted or locked up if this happened without so much as a sorry!

After you have installed the program, you will probably want to configure it. This is where you choose the video resolution, boot up disk options, and mouse, serial, and parallel port options. While you could run QPC and configure the program by copying it to floppy and running the standard pointer environment Config program on it, the easiest method is to run the PC based CONFIG.EXE program that comes with QPC. Again, this is a simple process. Note that if you have a serial port based mouse, you need to set the serial port that it uses to none. For most people the defaults given for the other ports will do nicely.

There is an improvement over the QXL hardware emulator when it comes to hard drive usage. The QXL only allows one QL hard drive per PC hard drive letter. On the other hand QPC lets you assign a file name for each QL hard drive that you wish to use. You could, if so inclined, actually have 8 separate QL hard drives (win1_ through win8_) actually existing on a single PC hard drive.

There is one more step required. QPC can not use any PC memory manager other than HIMEM.SYS. Therefore you might have to change your PC's CONFIG.SYS & AUTOEXEC.BAT files. Instructions are included for doing this with sample before and after file listings. Most people should not have any problems with it. The samples use the boot menu capabilities that come with DOS 6.0 or higher. This allows you at boot up to choose your normal configuration or the modified QPC configuration.

There are a few minor errors in the new file listings (at least they were errors on my system). If

you get an error when rebooting your machine after you do the change, just check it against your DOS manual. Here are the errors that were in my copy (they might be gone by the time you get yours): CONFIG.SYS file:

BUFFERS=0,15 -> should be BUFFERS=15,0

PATH=... -> this should be in AUTOEXEC.BAT

Make sure that you set the country to your country in CONFIG.SYS. The sample is set to 044 (England). USA is 001 and Germany is 049. Other country codes are found in the DOS manual.

In the AUTOEXEC.BAT file example, the KEYB (keyboard) is set to Germany. Make sure that you set this to your country (USA=US, United Kingdom=UK). I actually left this line out of my file and everything was okay. I however did include a 'KBD_TABLE USA' line in my QDOS boot file.

While the next item is in the manual, I still missed it. The CONFIG.SYS example sets the /INT15=4096 for the HIMEM driver. This is the amount of memory reserved for QPC. When I used this but tried to configure QPC to use 8K (8192), I got an error message and QPC reset to 4K (4096) and continued to start (this was a nice way to handle this error). When I changed the value to 8192, QPC gave me that much memory and was happy to do so. Just make sure that you don't set a value higher than you physically have on your computer.

Copy Protection: This is the one issue that always gets my dander up, the need (or perceived need) for copy protection. Copy protection is usually added to a program because too many people borrow copies and never pay for them. It has always been my personal belief and hope (maybe I am living in a make believe world) that any program that is high quality, useful, and reasonably priced should not require copy protection. People should be willing and even happy to pay for it.

Unfortunately, those powers to be (and this is their right) decided that QPC needs to have copy protection. The negative side is that you must always work off the original disk. Making a backup safety disk won't work.

However, this should not be a problem for most people. QPC's copy protection has been reasonably well thought out. It comes with two installable copies. For most people, the second copy will be used as a backup just in case your hard disk is corrupted (fairly rare). In my case I installed one copy on my laptop and one will go on my office computer (I have a QXL on my home desktop computer already). I am using the two copies but will only be using one at a time, therefore not violating any rules. Note that if you plan to have both copies installed on different computers, please make sure that only one is in use at a time. You should own a separate copy for each user of the program. This is only fair to the authors.

If you plan to remove a copy and put it on another computer, this is very easy. When you run install and it finds that you have already installed a copy, it gives you an option to install the second copy (if still available) or to de-install the copy. If you choose de-install, it takes the copy from your computer and adds it back into the QPC floppy disk as available. You can then install it on another computer as usual. NOTE: do NOT just delete QPC from your computer. If you do, you loose that copy, period.

Let's consider two scenarios that might be of concern. Let's say that your floppy is corrupted. For those of you who have done business with Jochen Merz (the distributor of QPC), you know that he is a reasonable person. His policy for corrupted or damaged floppies just requires that you return the original for fixing or replacement.

As to upgrades. You will be able to install the upgrade onto your original floppy or better yet, upgrades will be installable directly onto the computer that QPC currently exists without having to de-install it first.

Video Modes: QPC currently supports four different video modes. Of course you can use the standard QL mode (512x256). In addition, the other three modes are EGA (640x350), VGA (640x480), and SVGA (800x600). The screen capture shown in this review is in 800x600 mode running on my laptop. As you can see, you can cram tons of stuff on your screen. Wonderful!

As I mentioned previously, your PC's video card must support SVGA 800x600 in 16 colors to run QPC in SVGA mode. If it only supports SVGA in 256 or more colors, you can not run QPC above the VGA resolution. There should be no limit as to who can run VGA or lower modes. Just about all 486 or above PC's support VGA and lower resolutions for the QPC.

A nice item (this is actually a SMSQ/E feature) is that you can change your video mode without restarting QPC. This is convenient is you are working late but normally use SVGA. When my eye sight starts failing, I tend to switch to VGA for the larger image. A note: you should never try to change your video mode to a higher resolution that you started QPC with. **[Jochen's note: why not? - it does work very well here!]**

Operating System: QPC ships with Tony Tebby's superb updated operating system, SMSQ/E v2.76. This is the same operating system that you can purchase to run on the Gold card, the Super Gold Card, the QXL, and the Atari. Tony is constantly updating SMSQ/E and updates will be made available to QPC owners. In fact, one of the delays in QPC to market was in making sure that it had the latest version of SMSQ/E included.

If you haven't used SMSQ/E yet, you will find that it includes the ToolKit II and the pointer environment built into it. It includes many performance improvements and the now well known SBASIC, an improved Super Basic interpreter. In

JUST WORDS!

Software for Writers and Word Lovers

".....the QL Writer's Package would rival any offered anywhere for any operating system."

QL Today.

Now Available:

QL-THESAURUS with USA database.

In Voorbereiding:

STYLE-CHECK NEDERLANDS.

The Complete Range:

SOLVIT-PLUS 2 <i>Dictionary for word puzzles</i>	£15
QL-THESAURUS <i>23,000 words in 1,000 groups.</i>	£15
STYLE-CHECK <i>Improves your writing style.</i>	£15
WORDS PACKAGE <i>(Solvit-Plus 2 + Thesaurus)</i>	£25
WRITER'S PACK <i>(Thesaurus + Style-Check)</i>	£25
ALL 3 PROGRAMS	£35

Available direct from the author, from QUO VADIS or from Q BRANCH.

Pay by sterling cheque drawn on UK bank, Eurocheque in guilders or International Postal Order.

(£5 = 13 guilders)

**Geoff Wicks, Bertrand Russellstraat 22, 1097 HL Amsterdam, Netherlands.
Tel: (31) (0)20 - 692 1521. Netherlands Bank: Postbank number 4111942**

fact, the performance section of this review shows how SBASIC actually ran the benchmarks faster than the QLIBed version of the benchmarks. Again, I recommend that you dig through some of your recent magazine issues and find the different reviews of SMSQ/E for more details.

Extras

As we all know, one of the really nice (and enduring) things about QDOS and SMSQ/E is the ability to add new commands and capabilities to it.

QPC uses this to supply extra capabilities that normally aren't found on the normal QL.

There are several commands that most versions of SMSQ/E include relating to hard and floppy disk usage, video modes and serial port usage (up to 57600 baud).

By far the most useful new commands (or maybe just the most enjoyable) are letting me listen to my favorite musical CD while I type this. A full series of simple basic commands have been added to let you access music CDs from your computer's CD player (assuming you have one). If you have loaded your DOS CD and sound card drivers before starting QPC, you can use commands such as CD_PLAY, CD_STOP, CD_RESUME, and CD_EJECT. Several other commands return information about the tracks, times, etc. A sample basic program is included to play your CDs. I expect someone will come out with a fancy CD program now (you perhaps?).

Performance

Performance means benchmarks. Benchmarks means misleading results. You have been warned, so here we go.

I ran two sets of benchmarks on QPC and a QXL hardware emulator card. QPC was run on two different computers. The first was a Gateway 2000 Solo laptop with a 100MHz Pentium, a SVGA resolution screen and local bus video. The second computer was my miscellaneous part sourced desktop with a 133 MHz Pentium, PCI video, VGA resolution (in SVGA mode, the 256 min color limit on my card bit me). The QXL used the same desktop computer and VGA resolution.

The benchmarks used were Dhrystone and MathBench, both downloaded from QBOX USA. The Dhrystone numbers (integer math and standard loop type test) are Dhrystones per second (an industry standard). For MathBench I ran tests B

through F. Only the summaries are included here. Test group 1-12 covers basic instructions and loops with simple math functions. Test group 13-17 runs compute intensive math functions such as LOG10() and SIN(). The results for MathBench are given as how much faster the tests ran compared to a non-modified QL. A word of caution should be used with the MathBench numbers, especially for the QXL. The MathBench loops are not very large and do not take too much time to run. The results are given in 1 second resolution. This can slightly skew the results for the QPC. On the QXL ran the tests so fast that the 1 second resolution of the results truncated the results down to 0 and 1 second per test. The numbers for the QXL are given to indicate its high speed but should be considered inaccurate.

MathBench tests B and C are run with SBASIC (SuperBasic on the original QL). Test C uses the integer variable of SBASIC to speed things up. Test D is a QLiberated version of the benchmark. Tests E and F are Turbo versions of the benchmark.

	<i>QPC Laptop 100 MHz</i>	<i>QPC Desktop 133 MHz</i>	<i>QXL Desktop 133 MHz</i>
Dhrystones	2212	3048	6849
MathBench, Group 1-12			
B: Basic	32.5	46.3	150
C: Basic, Int Var	34.8	40.0	162
D: QLIB	30.4	43.3	139
E: TURBO, Brief	38.5	130	xx
F: TURBO, Fast	122	177	xx
MathBench, Group 13-17			
B: Basic	12.9	17.4	49.7
C: Basic, Int Var	12.9	17.4	49.7
D: QLIB	15.1	20.5	49.7
E: TURBO, Brief	15.1	20.5	xx
F: TURBO, Fast	15.8	23.2	xx
MathBench, Summary			
B: Basic	26.4	37.0	115
C: Basic, Int Var	27.7	38.9	121
D: QLIB	26.3	37.0	109
E: TURBO, Brief	51.0	71.8	xx
F: TURBO, Fast	60.4	88.3	xx

Looking at the table, the Dhrystone results show the expected difference between the laptop and desktop machines. The difference is partially due to the faster processor. Additionally, all laptops are power stingy and therefore compromise some performance for power savings. The QXL numbers on

the same desktop show performance results at about twice that of QPC on the same machine.

MathBench gives a better breakdown of the performance. It can be observed that the BASIC versions actually ran faster than the QLIBERATED version. This is due to the much improved SBASIC which is part of SMSQ/E that comes with QPC and which was purchased separately for the QXL.

The MathBench Summary provides a good overall performance comparison. Disregarding the TURBO section (not all TURBO programs run under QPC or QXL due to 'short cuts' they took to speed things up), the QPC on the slowest machine tested here was 26 times as fast as the original QL! For the desktop machine it was 37 times as fast. A 486 DX2 running at 66 MHz can probably achieve 1/3 the speed of the Pentium 133 MHz used here (conservative estimate). This would result in a performance of 18 times the speed of the original QL. As far as emulators go, this is hot stuff!

The original 16 MHz Gold Card expansion speeds up the QL by a factor of about 7. The Super Gold Card has even better performance, speeding things up to about 14 times the original QL's speed. Using these approximations, the QPC on a 486 DX2 66 MHz speed should compare favorably with the Super Gold Card enhanced QL!

Since numbers definitely do not tell the entire tale, I will give some descriptive meaning to them as per my experience so far.

I ran quite a few programs on my laptop for this review. The screen capture shows just a few, including ProWesS and Pointer based programs, a game, an editor, and a separate SBASIC window.

The biggest test of performance is when I ran the newly released ProWesS [PWS] package. This is a very computer intensive vector window management and font package. With my laptop plugged in (on battery mode, it runs slower, depending on the power saving options selected), this software ran acceptably well. It was not as fast as I would like, but it was definitely useful. The only 'painful' delay occurred when ProWesS first generated a font. However, ProWesS caches fonts. After the first font usage, ProWesS ran smoothly. ProWesS on my desktop version of QPC ran well.

In viewing a more commonly used (so far) front end package, the pointer environment ran as smoothly as one could wish for. All of the other packages I tried ran without a hitch and I can not complain about their performance.

Most software should run fine, even on a 486 machine. My gut feel is to caution running something like the ProWesS package unless you had a 486 DX2 or better. The performance of QPC is remarkable. Even though it can't compare to the QXL hardware emulator, it runs much faster than the original QL and has horse power enough

to run just about any QL application on most 486 or better machines.

Programs

I threw quite a few programs at QPC and have found no problems so far. But I need to qualify that statement.

QPC runs SMSQ/E, not QDOS. Therefore many of the older programs that cheated (this includes many TURBO compiled programs and some early games) are not compatible. All the programs that I run today worked without a hitch. Some of the early QUANTA library programs do not run (at least so far). For those of you who have been updating your hardware over the years, the same programs that quit working with your new hardware probably will still not work under QPC.

The following list is a sampling of what I ran so far under QPC:

Cueshell, Text87, QLReader, QPAC I,II, QD, QTPI, HyperHelp, XChange, Unzip, C68, Line-Design, MineField, EasyPtr, Ungif, Misc Pointer Utils, DISA, Engif

Comparison to QXL

Once deciding that an emulator is a must buy, it is necessary to determine whether the software version (QPC) or the hardware version (QXL) is right for you. For me, it was easy, I bought both. But let's say you are not as liberal with your hard earned money as I seem to be.

Before looking at the usage part of the decision, two performance items need to be brought up, other than raw speed. The QXL depends on a slow bus connection to the PC hardware (the good old AT bus). Two noticeable performance items occur due to this that QPC does not suffer from. The QXL can have moderately jerky screen updates in certain conditions. It also has relatively slow floppy disk access. The QPC has very smooth screen refreshing and its floppy disk access (for both QL and PC formats) is noticeable faster than the QXL's.

If you need portability, QPC is probably the right choice. QXL can fit some of the older PC laptops but that option amounts to more power consumption and therefore less time (if any) on a battery. Also, I don't know of any laptop that is color which will take the QXL card.

For a desktop choice, the QXL does have advantages. First and foremost, it is definitely faster (approximately x2 on my desktop system). It can also be run from Windows and OS/2 (in full screen mode only) without having to reboot the system to DOS. However, the QXL is more expensive. If you are planning to use a lot of high end graphics (such as Line Design or ProWesS) or are planning to run large simulations or large C68 compiles, the QXL

might warrant the cost. But if the cost of a QXL is too high for you at this time, QPC works just fine.

Another consideration, if you insist that your computer play your Audio CD's while you work, you have to use QPC. QXL does not support audio CDs at this time.

For the power hungry, the QXL is also the choice. But even my power desire can not justify two QXL cards so I use a QXL on my home desktop and QPC at the office and in my laptop.

Laptop Usage

Even though QPC uses an unusual memory management scheme, it seems to be compatible with my laptop's power saving circuitry. Perhaps this is due to the power saving code being part of the BIOS. If your laptop of choice was made in the last few years and therefore follows the standards, it should give you the advantages of the power saving circuitry while running QPC. If your laptop is older, you might check to ensure that the power saving circuitry is BIOS based. Even if it is not, it might still work but is up to you to find out.

Another item for laptops is how they manage shutdown/power standby modes. During standby, everything is literally shutdown. Normally this might cause trouble with software that maintains its own time (such as QPC). However, QPC

updates its clock with the systems real time clock every three minutes. The longest the QPC clock could be wrong after a stand-by mode shut down is just three minutes.

I also found that on my laptop, the SVGA mode is perfect for viewing. I get excellent resolution and SVGA mode completely fills my screen.

My laptop includes the touch screen pointer device which uses the standard mouse drivers. It also adds a 'double tap' capability which is the same as pressing the left mouse button. This works with no problems at all under QPC. I suspect any other mouse 'substitute' that uses the standard mouse drivers will also work with QPC.

I did find one problem with my particular laptop and the Audio CD routines. When I shut my laptop while playing a CD, the laptop goes into suspend mode. As expected, the CD stopped playing. However, when I resumed operations, QPC was locked. This is easily avoidable by typing CD_STOP before shutting your laptop lid. Simple enough.

Final Notes

As you have probably guessed by now, I am definitely recommending QPC for anyone with the need for a portable QL or another QL on a desktop who must use a PC for work. For the

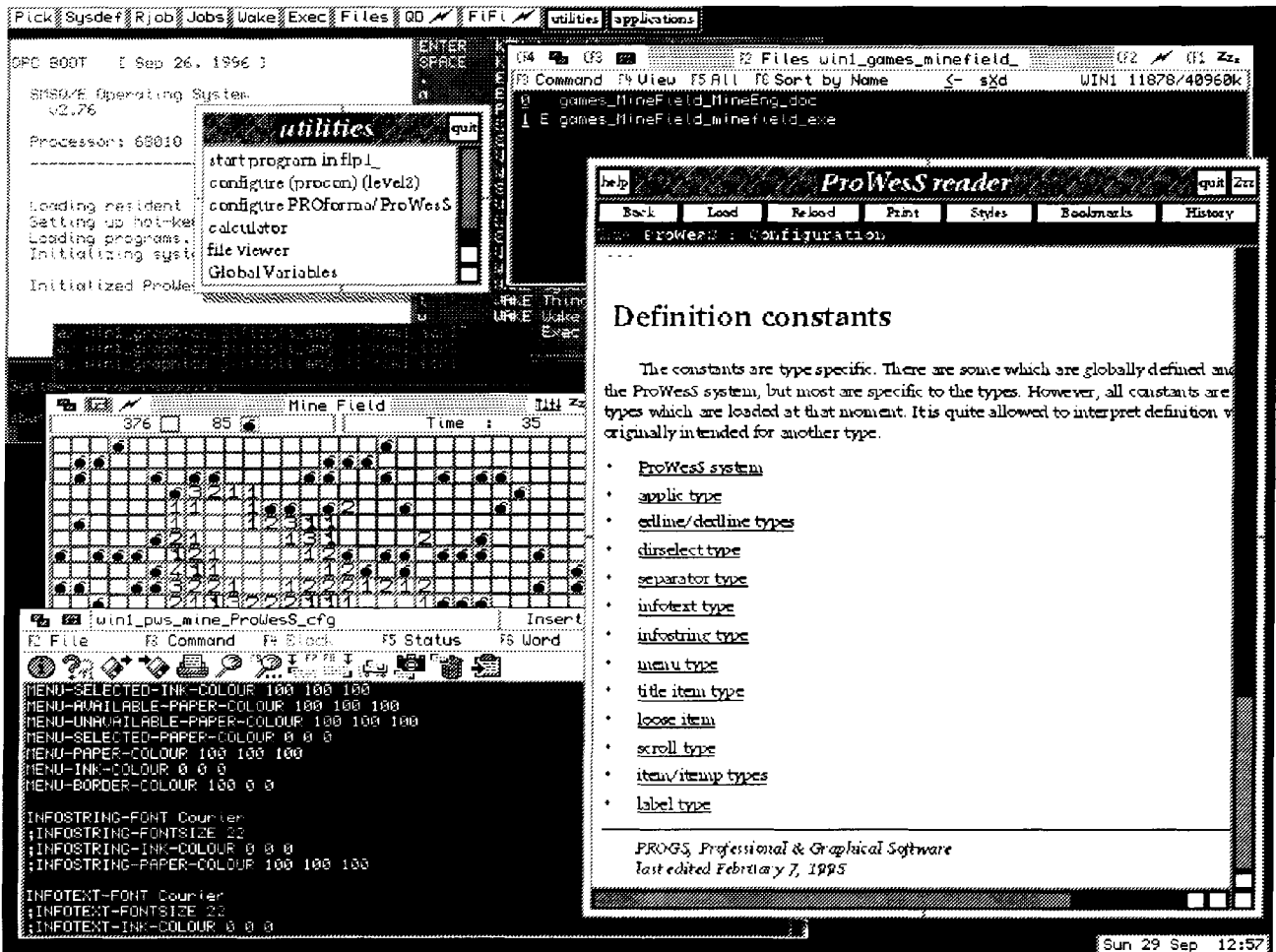

desktop, it comes down to your choice between the lower cost QPC option or the QXL's better performance (assuming that you are using SMSQ/E on the QXL).

I have had only two problems with QPC (other than NOT reading the manual). The first was related to shutting down my laptop while QPC was playing an audio CD, as discussed previously. The second is that my desktop version of QPC does not find the serial mouse. To be fair, I have dedicated the time for this article to testing primarily on my laptop and running different programs. I probably will find that I didn't follow instructions for the mouse. If it continues to be a problem, I can depend on Jochen Merz to help solve it! Overall considering what I have put QPC through, it performed is performing well beyond my expectations!

QPC is very well done, simple to use, and provides excellent current compatibility through the use of SMSQ/E as its operating system.

Extra Information: This article was written with Text87Plus4 [by Software87] on QPC [by Marcel Kilgus] running on a Gateway2000 Solo Laptop Computer. The screen capture was done with Engif [by Dr. Carlo Delhez] on the same computer with QPC, 600x800 resolution. The copy of QPC used is not an evaluation copy but one purchased by me, the author. This is obviously the best endorsement I can give.

Just Tested... the new release of OS/2 Ver 4.00 (Merlin) runs QPC under the Dedicated Dos option. This effectively shuts OS/2 down and starts a normal DOS mode (V7.00 modified) which allows QPC to run normally. When you are finished with a QPC session, your system will restore your OS/2 desktop to where you left it. This entire process is MUCH faster than using Dual Boot for running QPC and is less stressful on your hard disk drive. QPC can actually now be started from a desktop icon.

One restriction is that you can not use the menu versions of the config.sys and autoexec.bat as suggested in the QPC documentation. The DOS support does not include this.



Last Minute News

STOP PRESS: (hot from the Byfleet QUANTA meeting from Jonathan Hudson)

Since writing the Future Imperfect article, some interesting developments have come to light.

Dave Walker has located the sources for the Linux "Java" virtual machine project. This is written in C and is easily portable to QDOS. The virtual machine is however only part of the "Java" environment; the potentially more difficult part is the sourcing of the runtime "Class Libraries" which would be QDOS specific.

Neither Dave or myself really has time to work on such a project; if you're interested in helping in bringing "Java" to QDOS then further information is available from Dave Walker (d.j.walker@x400.icl.co.uk) or Jonathan Hudson (jrh@jrudson.demon.co.uk). Specific skill requirements include 'C'/Pointer Environment. Internet access to track the progress of the Linux Java team would also be helpful.

News from QUBBESOFT P/D

Ron Dunnnett informs us that no more stocks of the SyQuest EZ-135 drives are available from the manufacturer, so Qubbesoft P/D are no longer able to supply the EZ-135 drives which have proved so popular with the Qubide IDE interface. The bad news is that although SyQuest have brought out a successor to the drive, called the EZ-Flyer, it is not currently available in an IDE model. Ron states that there is no problem with the supply of the 135MB cartridges, these will continue to be available.

QL Users Email Database

Tony Firshman has suggested we create a common list of QL User Email addresses rather than the separate lists currently held by various traders etc.

To implement this, I have volunteered (?) to maintain and despatch updated lists to interested parties using the same automated system currently in place.

If you do not wish to have your Email details made available on this list please let me know.

Robin Barker eMail: di-ren@di-ren.co.uk

Q-emuLator News

There's now a Q-emuLator support site on the World Wide Web:

<http://www.geocities.com/SiliconValley/Heights/1296/q-emulator.html>

New Q-emuLator versions 1.1 (68K Macs) and 2.1 (Power Macs) have been released, with added mouse emulation under the Pointer Environment.

Registered Q-emuLator 1.x users can download the 1.1 updater at the above WWW address. Registered Q-emuLator 2.x users can request to me to receive the new 2.1 version as an e-mail attachment (it is quite long).

Q-emuLator 3.0 will be ready in a few months. This version is for 68000 Macs only and is about twice as fast as Q-emuLator 1.1 thanks to an extensive rewrite in machine language of the emulation engine.

Daniele Terdina

e-mail: sistest@ictp.trieste.it

Feedback is always welcome!



UQLX

Richard Zidlicky

UQLX is a QL emulator for UNIX and unix-like systems with X11. It is not very long ago that I was deeply convinced of the impossibility to emulate a 68000 CPU reasonably fast by software - not to say by the means of a portable language like c. But a little experimentation with STonX running QLemm on a SUN SPARC convinced me that it can be still a lot faster than a QL if run on a very fast machine. So the experiments went on. STonX at that time did a very good job emulating Atari ST software, but its CPU emulation wasn't good enough for QL software, so I decided to use Daniele Terdina's 68000 emulation engine instead. This was well tested and very stable running QL software and also had the advantage that Daniele allowed me to use part of his QDOS patches and handlers. The disadvantage was its rather uncertain portability as it was not designed to deal with problems like byte order or alignment requirements of different architectures. This didn't worry me too much at that time when I intended the emulator only for my own use on SPARC machines but resulted in a few problems later porting it for Intel or the 64 bit Alpha CPUs. Fortunately, the emulator sources were small enough to make it relatively easy to fix.

The big strength of UQLX is that it will work on nearly any hardware and integrate neatly with most unix(-like) operating systems, allowing QDOS programs access to the underlying file-systems. Meanwhile UQLX has been tested on SPARC, PPC, HP-PA, MIPS and Intel i486 or better CPUs running various UNIX makes, the only requirements to get it running is gcc and Xwindows. gcc proved essential to the project, with its many extensions to ANSI c it provides a stable and portable platform for many special optimisations not possible in ANSI or K&R c. Without such optimisations a 68000 emulator written purely in c would probably be much too slow to be useful on many low end systems. Even in this early stage with lots of optimisations and gcc tricks still waiting to be applied UQLX runs approximately

with the 5x speed of an original QL on a 166 Mhz clocked Pentium.

UQLX is still in its early development phase, screen mode 4, JS-ROM and TKII support, floppy disk and host file system access, up to 4MB RAM and real time clock already work, the rest of QL features is in development. The host filesystem access already allows access and creation of UNIX directories by emulating the FileSystem II operation. The 68000 emulation is the same quality as Daniele's emulator, therefore I expect that UQLX will provide a platform very compatible to an original QL with a few extensions. Later I would like to add mouse support and cut and paste between QDOS and X applications via hotkey buffer, scratch or directly into keyboard queue.

UQLX is shareware and its sources will be available through the Internet so it may become an interesting object for hackers as well. A first beta release is scheduled for November, alpha releases are available by email from

rdzidlic@cip.informatik.uni-erlangen.de



Editor's last word

Again, this issue is absolutely full of amazing news and articles. We could not fit in all the articles which arrived, so some have to wait for the next issue. This should not stop you writing and sending in articles, 'cause we want to fill much more QL Today's in the future.

Yesterday, I've [**Jochen**] learned a lesson: after having formatted my harddisk by mistake a long time ago (I was planning to format a removable medium instead) I lost some work because my backups were 2 weeks old. From then on, I'm always doing my SMSQ Backups. Due to a broken SCSI cable I nearly lost the complete issue of QL Today because I somehow suppressed making backups of the TOS partitions. Bad news - I probably never was as desperate as yesterday! With a lot of work, I managed to retrieve all the important files, but I don't want to make this experience again! For your own sake: always make your Backups!

So far we received 5 entries for the Puzzler - either it takes longer to solve it than we thought or it is simply too difficult. Therefore, we think it is a good idea to allow the results for Puzzler to be returned until 15th of December, and the winner will be published in issue 5.

All that remains now is: hope you enjoyed reading issue 4 as much as we did while creating it,

The Editors.

Di-Ren

Worldwide QL Internet Resource

<http://www.di-ren.co.uk/ql/homepage.htm>

Email: di-ren@di-ren.co.uk (New address)

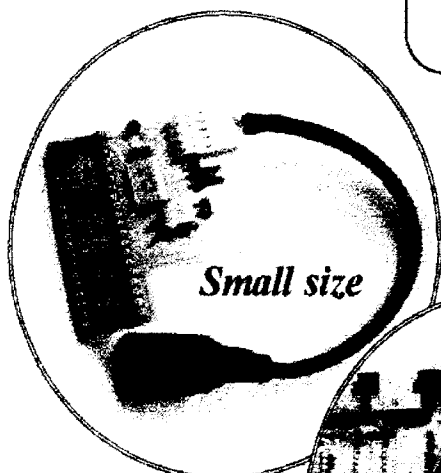

Small size

Easy to fit

ACCESS
VISA
MASTERCARD
EUROCARD

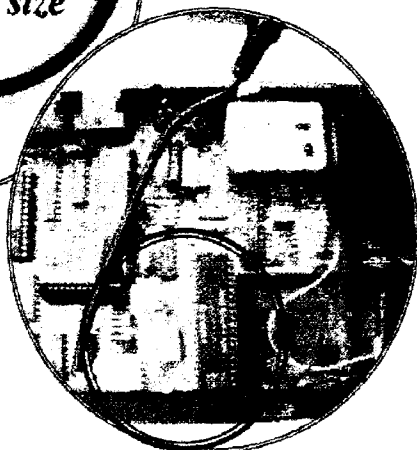

The QL's Best Selling Keyboard Interface Only £32.50

**Enables PC/AT 101 and 102
key keyboards to be fitted
to your QL!**

102 Key Enhanced Keyboard: £24.00

Price changed as from November 1st

Post & Packing:	UK	Europe
Without Keyboard	£1.50	£2.00
With Keyboard	£4.00	£5.00

Enquire for elsewhere

Amadeus Interlink

Fast, efficient networking.

Connect up to 254 interfaces!

QL interfaces connect your QL to the system.

Centronics Controllers for connecting PC's.

Centronics Interfaces for printers and bi-directional communication.

Sound Interfaces for recording and replaying real sound.

Enquire for further details

Di-Ren
"Jelanda"
Wyndley Drive
Sutton Coldfield
B73 6EU
Great Britain

<http://www.di-ren.co.uk/ql/qisale> for sales and wants!

Di-Ren Internet Web Site files now available by Email.

For information send the following Email Message:

Email to: di-ren@di-ren.co.uk

Message to read: AUTO SENDFILE help.txt

Tel/Fax +44 (0)121 355 3943

Please note we are closed:
25th November to the 16th December
24th December to the 2nd January

**THE
EDITORS OF
QL TODAY
WISH EVERY**

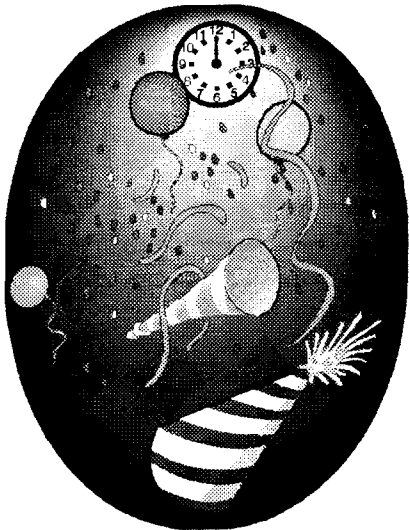

**QL-USER A
MERRY
CHRISTMAS AND
ONLY THE VERY
BEST FOR 1997!**

BRISTOL QL WORKSHOP

Sunday 17th Nov. 1996

10am to 4pm

at

**Somerset Hall, Portishead, Nth Somerset
(off junction 19 of the M5)**

- * *All the major QL traders present*
- * *The famous Bristol Bring 'n Buy*
 - * *Help and Advice Clinic*
 - * *Talks and lectures*
- * *Theatre style presentations*
 - * *Free parking*
 - * *Refreshments available*

*not to mention the friendly and helpful welcome
from Quanta and the Bristol QL Users Group*

**For further information, hotel availability,
directions etc. please telephone Mike
Ashford on (01934) 415416**

The Bristol QL User Group are pleased to announce that arrangements are now well in hand to present the following activities at the above workshop:

- * *Graphical and DTP software on QL, by a well-known QL personality*
- * *SuperBASIC programming, by our resident expert.*
- * *An introduction to Machine Code programming by an experienced programmer.*
- * *An overview of the Pointer Environment and the capabilities offered, by a well-known QL expert.*

An opportunity to get answers to all those questions you always wanted to ask. Don't miss out. Come to Portishead on Sunday 17th November. The Bristol QL User Group and Quanta look forward to welcoming you there.